













Contents

■ Storage tank NAD v1	1
■ Storage tank NAD v2	3
■ Storage tank NAD v3	4
■ Storage tank NAD v4	5
■ Storage tank NAD v5	6
■ Storage tank NADO v1	7
■ Storage tank NADO v2	10
■ Storage tank NADO v3	12
■ Storage tank NADO v6	13
■ Storage tank NADO v7	15
■ Storage tank NADO v9	17
■ Storage tank UKV NIBE	18
■ Heat insulation of the utmost quality	19
■ Original parts from Dražice	20
■ Company History	24

Legend to Icons

Inlets		Outlets	
Solid fuel boiler		Floor heating	
Biomass boiler		Radiator	
Fireplace insert		Hot water	
Electric heating – dry ceramic unit TPK 210/12			
Electric heating – wet unit TJ 6/4"			
Heat pump			
Photothermic solar system			
Photovoltaic solar system			

Tolerance of all stated dimensions complies with ČSN ISO
Z/T circuit socket = socket of heating sources and heating circuits

* The value is derived by calculation

Storage tank NAD v1 (types 50, 100, 250)



- New product NAD 50 v1
- Types: 50, 100, 250
- The tank is supplied with non-detachable insulation
- Suitable as an equalization tank for heating systems with solid fuel boilers
- The TJ 6/4" heating unit can be mounted into the socket



Socket dimensions	NAD 50v1	NAD 100v1	NAD 250v1
Socket 1	1" female thread		1" female thread
Socket 2	1½" female thread		½" female thread
Socket 3	1" male thread		1" male thread
Socket 4	–		1½" female thread

Technical parameters		NAD 50v1	NAD 100v1	NAD 250v1
Order number		110580391	110880302	110980391
Heating water volume in tank	[l]	50	120	265
Weight	[kg]	25	41	63
Max. operating temperature / pressure in tank	[°C] / [bar]		90 / 3	
Insulation thickness (Polyurethane)	[mm]		42	
Heat conductivity of insulation (Polyurethane)	[W·m ⁻¹ ·K ⁻¹]		0,022	
Insulation order number (Polyurethane)			tank component	
Max. number × output of TJ 6/4"	[ks] × [kW]	1 × 3,3		1 × 6
Energy efficiency class (Polyurethane)			B	C
Standing loss (Polyurethane)	[W]	31	41	88

Tank dimensions		NAD 50v1	NAD 100v1	NAD 250v1
Tank diameter with insulation	∅ D	524	584	584
Tank diameter	∅ d	440	500	500
Total tank height	L	561	807	1570
Tilting height	L _k	–	–	1605
Tank height	H	–	–	1541
Discharging connection	A	215	226	–
Z/T circuit socket	B	345	576	228
Z/T circuit socket	C	265	401	828
Z/T circuit socket	E	365	556	1308
Sensor pocket socket	F	–	–	228
Sensor pocket socket	G	–	–	952
Sensor pocket socket	I	–	–	1308
Flange socket	J	–	–	–
Spacing of user-type suspension	R	300–310, 350–372, 432–468		

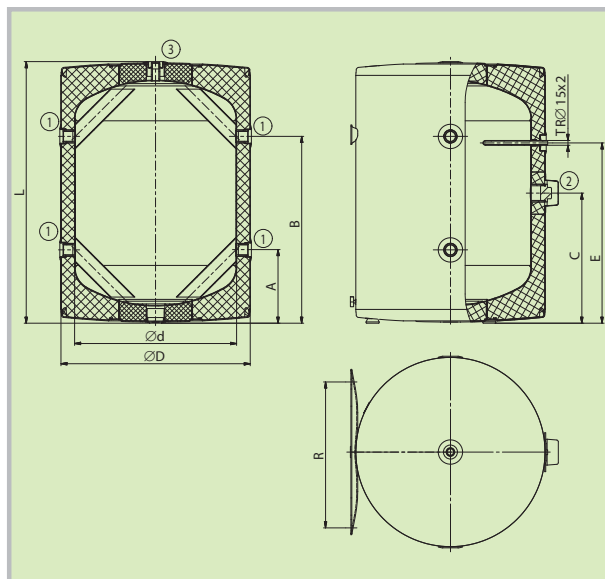

NAD 50v1, 100v1

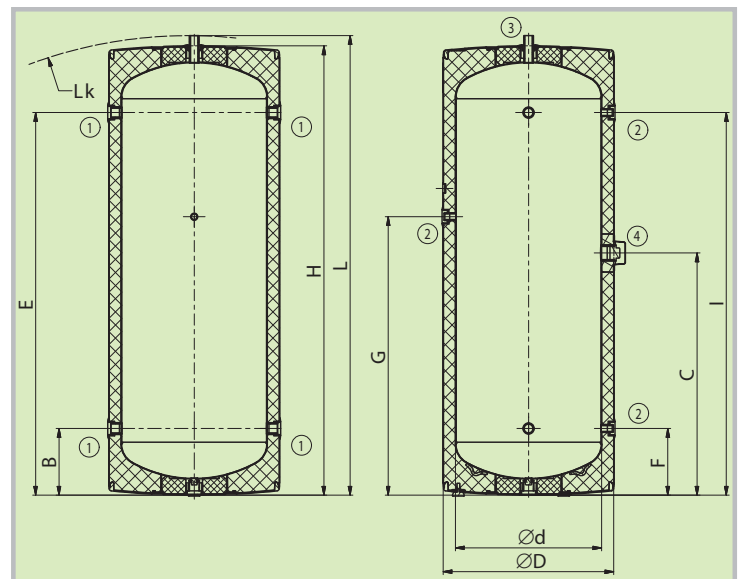

NAD 250v1

Storage tank NAD v1 (types 500–2000)



- Types: 500, 750, 1000, 1500, 2000 l
- Modern Neodul insulation can be ordered
- Suitable as an equalization tank for heating systems with solid fuel boilers
- The TPK 210/12 heating unit can be mounted into the flange
- We can supply 2 more custom made flanges for the tank
- The TJ 6/4" heating unit can be mounted into the socket

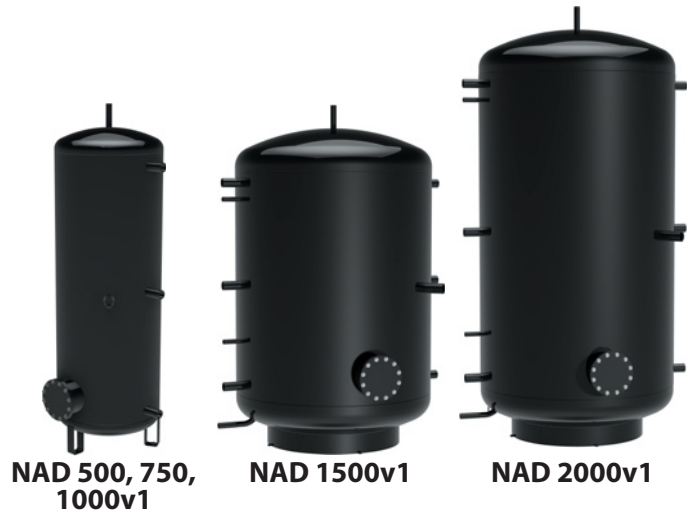

Socket dimensions	NAD 500v1	NAD 750v1	NAD 1000v1	NAD 1500v1	NAD 2000v1
Socket 1 – female thr.			1¼"		
Socket 2 – female thr.			½"		
Socket 3 – male thr.			1"		
Socket 4 – female thr.			1½"		

Technical parameters		NAD 500v1	NAD 750v1	NAD 1000v1	NAD 1500v1	NAD 2000v1
Order number		121380393	121680393	121580393	122180393	122280393
Heating water volume in tank	[l]	475	772	999	1507	2007
Weight	[kg]	85	109	126	204	247
Max. operating temperature / pressure in tank	[°C] / [bar]	90 / 3				
Insulation thickness (Neodul LB PP)	[mm]	80			100	120
Heat conductivity of insulation (Neodul LB PP)	[W·m ⁻¹ ·K ⁻¹]	0,032				
Insulation order number (Neodul LB PP)		6231902	6231904	6231905	6231710	6231711
Max. number × output of TPK 210-12	[ks] × [kW]	1 × 12				
Max. number × output of TJ 6/4"	[ks] × [kW]	1 × 9				
Energy efficiency class (Neodul LB PP)		C				
Standing loss (Neodul LB PP)	[W]	83	122	135	165	185

Tank dimensions		NAD 500v1	NAD 750v1	NAD 1000v1	NAD 1500v1	NAD 2000v1
Tank diameter	∅ d	600	750	850	1100	1100
Total tank height	L	1974	2022	2035	1906	2436
Tilting height	L _k	1994	2035	2050	1925	2480
Tank height	H	1846	1895	1905	1778	2307
Discharging connection	A	100	90	90	135	135
Z/T circuit socket	B	270	272	292	350	350
Z/T circuit socket	C	958	960	980	910	1175
Z/T circuit socket	E	1645	1646	1666	1470	2000
Sensor pocket socket	F	505	508	527	600	600
Sensor pocket socket	G	1555	–	–	1380	1910
Sensor pocket socket	I	937	1556	1576	895	1160
Flange socket	J	353	361	–	–	–
Flange socket	M	–	–	–	450	450

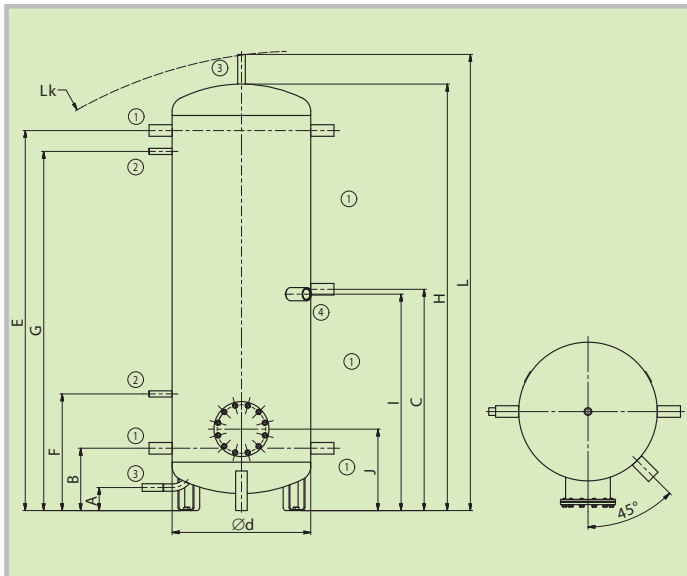

NAD 500, 750, 1000v1

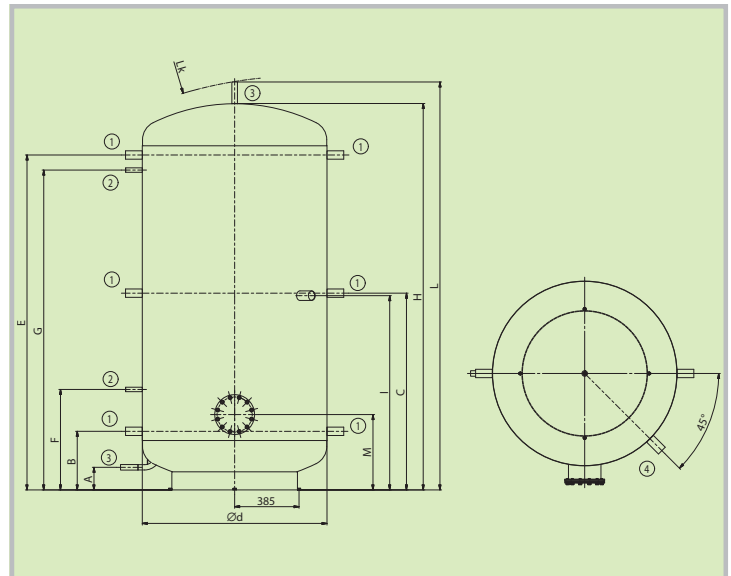

NAD 1500, 2000v1

Storage tank NAD v2



- Types: 500, 750, 1000, 1500, 2000 l
- The tank is supplied without insulation
- Modern Neodul insulation can be ordered
- Suitable as an equalization tank for heating systems with solid fuel boilers
- The TJ 6/4" heating unit can be mounted into the socket

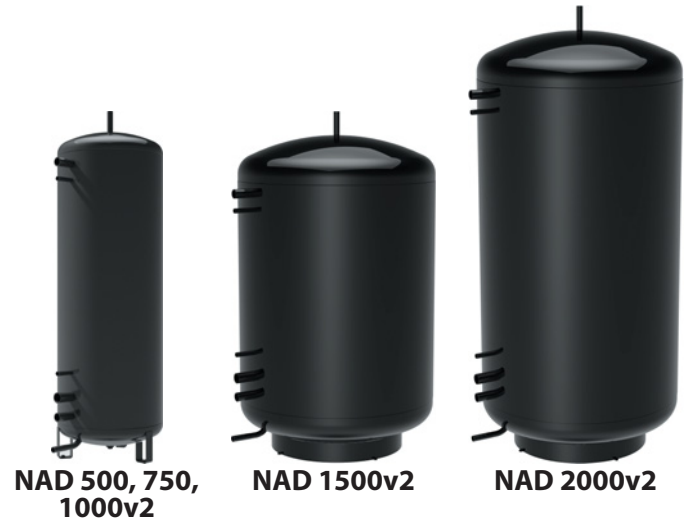

Socket dimensions	NAD 500v2	NAD 750v2	NAD 1000v2	NAD 1500v2	NAD 2000v2
Socket 1 – female thr.			1 1/4"		
Socket 2 – female thr.			1/2"		
Socket 3 – male thr.			1"		
Socket 4 – female thr.			1 1/2"		

Technical parameters		NAD 500v2	NAD 750v2	NAD 1000v2	NAD 1500v2	NAD 2000v2
Order number		121380394	121680394	121580394	122180394	122280394
Heating water volume in tank	[l]	475	772	999	1507	2007
Weight	[kg]	76	101	114	192	235
Max. operating temperature / pressure in tank	[°C] / [bar]	90 / 3				
Insulation thickness (Neodul LB PP)	[mm]	80			100	120
Heat conductivity of insulation (Neodul LB PP)	[W·m ⁻¹ ·K ⁻¹]	0,032				
Insulation order number (Neodul LB PP)		6231908	6231913	6231909	6231712	6231713
Max. number × output of TJ 6/4"	[ks] × [kW]	1 × 9				
Energy efficiency class (Neodul LB PP)		C				
Standing loss (Neodul LB PP)	[W]	83	122	135	165	185

Tank dimensions		NAD 500v2	NAD 750v2	NAD 1000v2	NAD 1500v2	NAD 2000v2
Tank diameter	∅ d	600	750	850	1100	1100
Total tank height	L	1965	2022	2035	1906	2436
Tilting height	L _k	1985	2035	2050	1925	2480
Tank height	H	1835	1895	1905	1778	2307
Discharging connection	A	90	90	90	135	135
Z/T circuit and sensor pocket socket	B	258	272	292	365	365
Z/T circuit and sensor pocket socket	C	1632	1646	1666	470	470
Sensor pocket socket	E	493	508	527	1470	2000
Sensor pocket socket	F	1542	1556	1576	600	600
TJ 6/4" heating unit socket	G	364	376	398	1380	1910

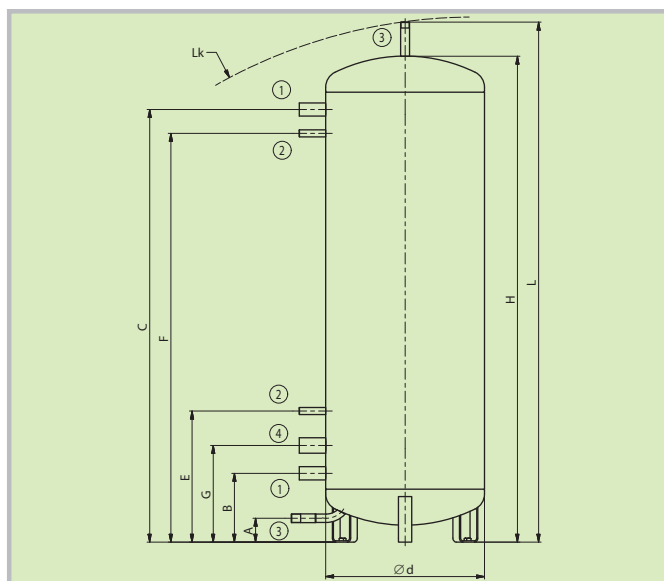

NAD 500, 750, 1000v2

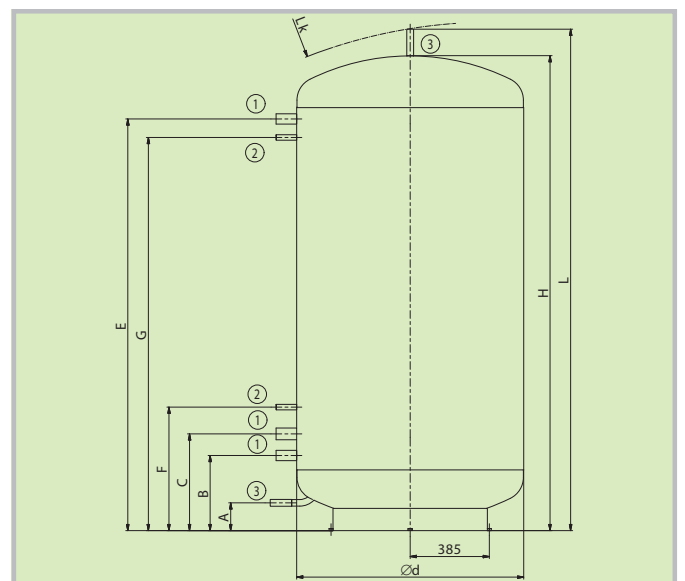

NAD 1500, 2000v2

Storage tank NAD v3



- Types: 300, 500, 750, 1000 l
- The tank is supplied without insulation
- Modern Neodul insulation can be ordered
- Suitable as an equalization tank for heating systems with solid fuel boilers
- The TPK 210/12 heating unit can be mounted into the flange
- The TJ 6/4" heating unit can be mounted into the socket



NAD 500, 750, 1000v3



NAD 300v3

Socket dimensions	NAD 300v3	NAD 500v3	NAD 750v3	NAD 1000v3
Socket 1 – female thread		1½"		
Socket 2 – female thread		½"		
Socket 3 – male thread		1"		

Technical parameters		NAD 300v3	NAD 500v3	NAD 750v3	NAD 1000v3
Order number		121080387	121380387	121680387	121580387
Heating water volume in tank	[l]	320	475	772	999
Weight	[kg]	60	87	110	126
Max. operating temperature / pressure in tank	[°C] / [bar]	90 / 3			
Insulation thickness (Neodul LB PP)	[mm]	80			
Heat conductivity of insulation (Neodul LB PP)	[W·m ⁻¹ ·K ⁻¹]	0,032			
Insulation order number (Neodul LB PP)		6231900	6231912	6231906	6231910
Max. number × output of TPK 210-12	[ks] × [kW]	1 × 12			
Max. number × output of TJ 6/4"	[ks] × [kW]	1 × 3,75 + 3 × 9	2 × 3,75 + 4 × 9	2 × 4,5 + 4 × 9	2 × 6 + 4 × 9
Energy efficiency class (Neodul LB PP)		C			
Standing loss (Neodul LB PP)	[W]	80	83	122	135

Tank dimensions		NAD 300v3	NAD 500v3	NAD 750v3	NAD 1000v3
Tank diameter	∅ d	550	600	750	850
Total tank height	L	1610	1965	2022	2035
Tilting height	L _k	1620	1985	2035	2050
Tank height	H	1480	1835	1895	1905
Z/T circuit and sensor pocket socket	A	245	258	272	292
Z/T circuit and sensor pocket socket	B	760	718	731	750
Z/T circuit and sensor pocket socket	C	1275	1176	1189	1208
Z/T circuit and sensor pocket socket	E	–	1632	1646	1666
Flange socket	F	–	341	357	375

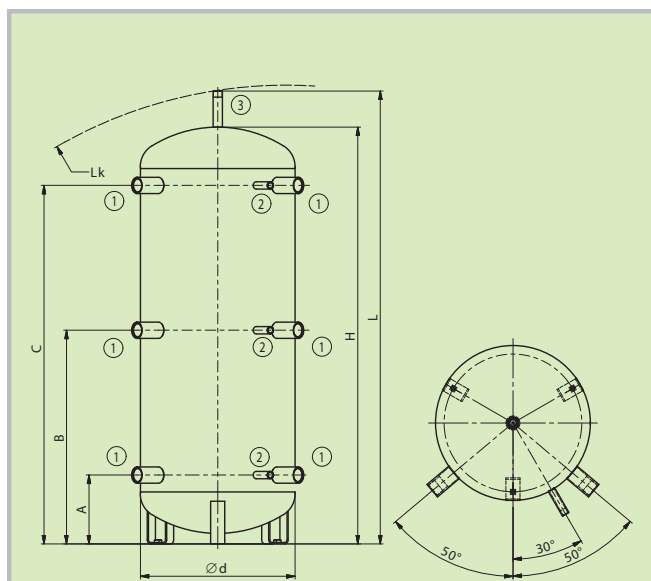

NAD 300v3

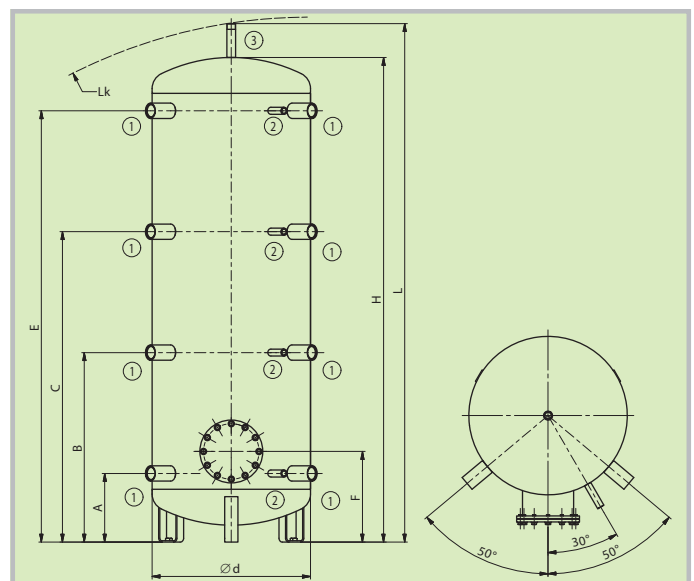

NAD 500, 750, 1000v3

Storage tank NAD v4



- Types: 500, 750, 1000 l
- The tank is supplied without insulation
- Modern Neodul insulation can be ordered
- Suitable as an equalization tank for heating systems with solid fuel boilers
- The TJ 6/4" heating unit can be mounted into the socket
- The TPK 210/12 heating unit can be mounted into the flange



Socket dimensions	NAD 500v4	NAD 750v4	NAD 1000v4
Socket 1 – female thread		1 1/4"	
Socket 2 – female thread		1/2"	
Socket 3 – male thread		1"	
Socket 4 – female thread		1 1/2"	

Technical parameters		NAD 500v4	NAD 750v4	NAD 1000v4
Order number		121380395	121680395	121580395
Heating water volume in tank	[l]	475	772	999
Weight	[kg]	110	135	149
Max. operating temperature / pressure in tank	[°C] / [bar]		90 / 3	
Heat transfer surface of exchanger	[m ²]		1,5	
Exchanger volume	[l]		10,5	
Max. operating temperature / pressure in exchanger	[°C] / [bar]		110 / 10	
Insulation thickness (Neodul LB PP)	[mm]		80	
Heat conductivity of insulation (Neodul LB PP)	[W·m ⁻¹ ·K ⁻¹]		0,032	
Insulation order number (Neodul LB PP)		6231902	6231904	6231905
Max. number × output of TPK 210-12	[ks] × [kW]	1 × 6		1 × 12
Max. number × output of TJ 6/4"	[ks] × [kW]		1 × 9	
Energy efficiency class (Neodul LB PP)			C	
Standing loss (Neodul LB PP)	[W]	80	119	133

Tank dimensions		NAD 500v4	NAD 750v4	NAD 1000v4
Tank diameter	Ø d	600	750	850
Total tank height	L	1965	2022	2035
Tilting height	L _k	1985	2035	2080
Tank height	H	1835	1895	1905
Discharging connection	A	90	90	90
Z/T circuit and sensor pocket socket	B	258	272	292
Z/T circuit and sensor pocket socket	C	946	960	980
Z/T circuit and sensor pocket socket	E	1632	1646	1666
Sensor pocket socket	F	493	508	527
Sensor pocket socket	G	1542	1556	1576
TJ 6/4" heating unit socket	I	925	940	960
Heat exchanger socket	J	348	368	382
Heat exchanger socket	K	876	896	910
Flange socket	M	341	357	375

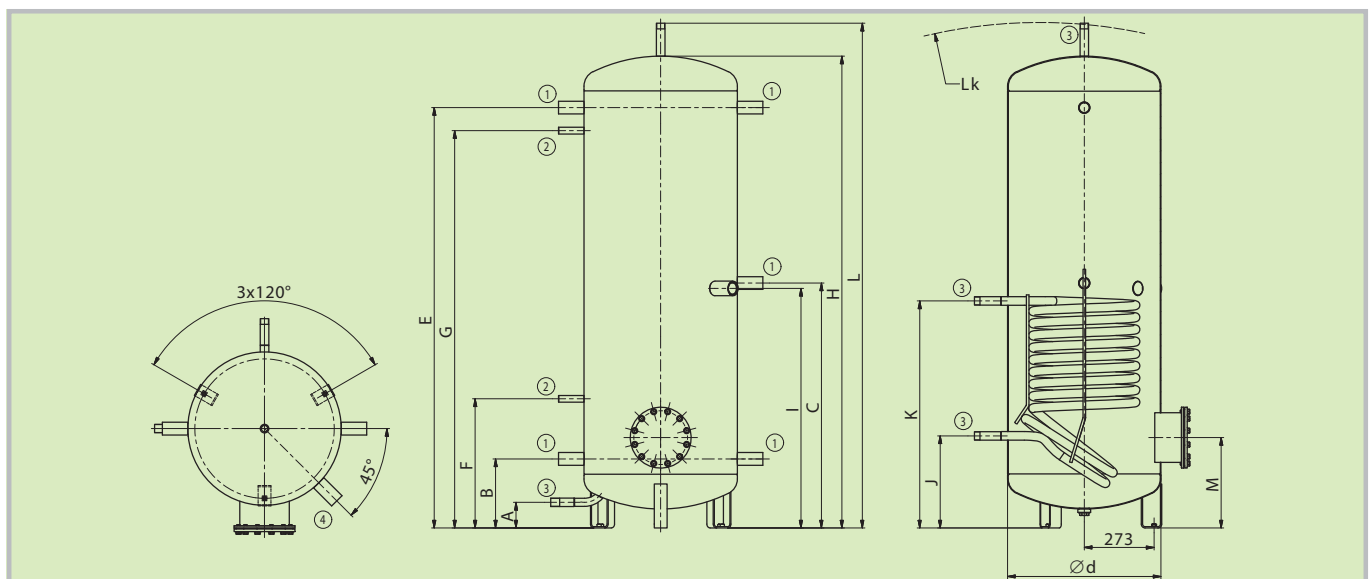

Storage tank NADO v1



- Types: 500, 750, 1000 l
- Inner HW storage tank in volumes of 140 and 200 l
- The tank is supplied without insulation
- Modern Neodul insulation can be ordered
- Suitable as a storage tank for heating systems with solid fuel boilers
- The TPK 210/12 heating unit can be mounted into the flange
- The TJ 6/4" heating unit can be mounted into the socket for 140 l version

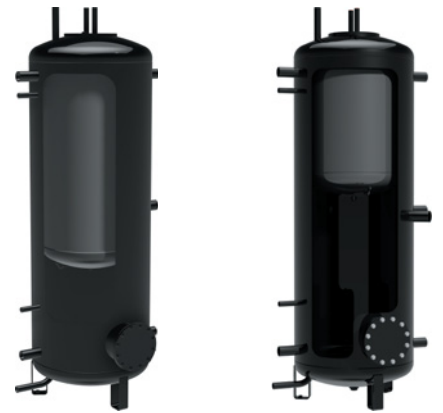

NADO 500/200v1 NADO 500/140v1

Socket dimensions	NADO 500v1	NADO 750v1	NADO 1000v1
Socket 1 – female thread		1 1/4"	
Socket 2 – female thread		1/2"	
Socket 3 – male thread		1"	
Socket 4 – female thread		3/4"	
Socket 5 – female thread		1 1/2"	

Technical parameters		NADO 500/140v1	NADO 750/140v1	NADO 1000/140v1	NADO 500/200v1	NADO 750/200v1	NADO 1000/200v1
Order number		121380315	121680315	121580315	121380397	121680397	121580397
Heating water volume in tank	[l]	475	772	999	475	772	999
Volume of storage tank for HW heating	[l]		140			210	
Weight	[kg]	113	137	152	127	151	166
Max. operating temperature / pressure in tank	[°C] / [bar]	90 / 3					
Max. operating temp. / pressure in HW storage tank	[°C] / [bar]	90 / 6					
Heat transfer surface of HW storage tank	[m ²]	1,43			1,95		
Capacity of hot water 40 °C at storage tank temp. 53 °C and inlet water 15 °C / HW flow rate*	[l] / [l·min ⁻¹]	260 / 5	490 / 5	750 / 5	260 / 10	490 / 10	750 / 10
Capacity of hot water 40 °C at storage tank temp 80 °C and inlet water 15 °C / HW flow rate*	[l] / [l·min ⁻¹]	650 / 5	1170 / 5	1450 / 5	650 / 10	1170 / 10	1450 / 10
Insulation thickness (Neodul LB PP)	[mm]	80					
Heat conductivity of insulation (Neodul LB PP)	[W·m ⁻¹ ·K ⁻¹]	0,032					
Insulation order number (Neodul LB PP)		6231902	6231904	6231905	6231902	6231904	6231905
Max. number × output of TPK 210-12	[ks] × [kW]	1 × 12					
Max. number × output of TJ 6/4"	[ks] × [kW]	1 × 9			–		
Energy efficiency class (Neodul LB PP)		B	C		B	C	
Standing loss (Neodul LB PP)	[W]	80	117	130	80	117	130

Tank dimensions		NADO 500/140v1	NADO 750/140v1	NADO 1000/140v1	NADO 500/200v1	NADO 750/200v1	NADO 1000/200v1
Tank diameter	∅ d	600	750	850	600	750	850
Total tank height	L	1970	2028	2040	1965	2022	2035
Tilting height	L _k	1990	2050	2060	1985	2035	2080
Tank height	H	1847	1903	1916	1835	1895	1905
Discharging connection	A	100	100	100	90	90	90
Z/T circuit socket	B	270	282	297	258	272	292
Z/T circuit socket	C	958	970	985	946	960	982
Z/T circuit socket	E	1644	1656	1671	1632	1646	1666
Sensor pocket socket	F	505	517	532	493	508	527
Sensor pocket socket	G	1554	1566	1581	1542	1556	1576
Flange socket	I	353	366	381	341	357	375
TJ 6/4" heating unit socket	J	937	950	965	–	–	–

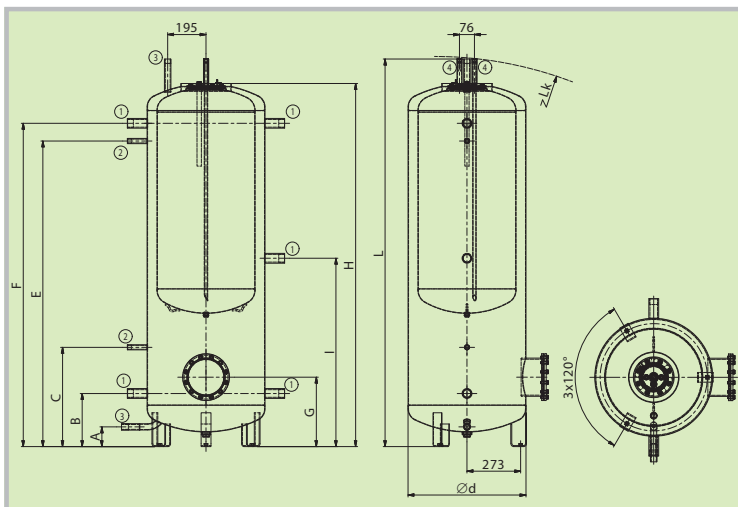

NADO 500/200v1

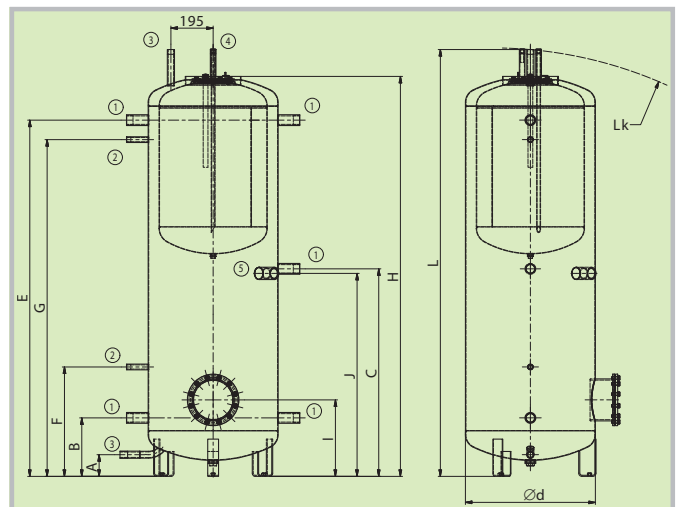

NADO 500/140v1

Storage tank NADO v1



- Types: 500, 750 l
- Inner HW storage tank in volumes of 300 and 250 L
- The tank is supplied without insulation
- Modern Neodul insulation can be ordered
- Suitable as a storage tank for heating systems with heat pumps
- The TJ 6/4" heating unit can be mounted into the socket



Socket dimensions	NADO 500/300v1	Socket dimensions	NADO 750/250v1
Socket 1 – female thread	1 1/4"	Socket 1 – female thread	1 1/4"
Socket 2 – female thread	1/2"	Socket 2 – female thread	1 1/2"
Socket 3 – male thread	1"	Socket 3 – male thread	1"
Socket 4 – male thread	3/4"	Socket 4 – male thread	3/4"
Socket 5 – female thread	1 1/2"	Sensor pocket \varnothing 15x2-150	

Technical parameters		NADO 500/300v1	NADO 750/250v1
Order number		121380314	121680314
Heating water volume in tank	[l]	475	772
Volume of storage tank for HW heating	[l]	279	260
Weight	[kg]	153	180
Max. operating temperature / pressure in tank	[°C] / [bar]	90 / 3	
Max. operating temperature / pressure in HW storage tank	[°C] / [bar]	90 / 6	
Heat transfer surface of HW storage tank	[m ²]	2,58	2,15
Capacity of hot water 40 °C at storage tank temperature 53 °C and inlet water 15 °C / HW flow rate*	[l] / [l·min ⁻¹]	260 / 10	490 / 10
Capacity of hot water 40 °C at storage tank temperature 80 °C and inlet water 15 °C / HW flow rate*	[l] / [l·min ⁻¹]	650 / 10	1170 / 10
Insulation thickness (Neodul LB PP)	[mm]	80	
Heat conductivity of insulation (Neodul LB PP)	[W·m ⁻¹ ·K ⁻¹]	0,032	
Insulation order number (Neodul LB PP)		6231947	6231915
Max. number × output of TJ 6/4"	[ks] × [kW]	1 × 9	3 × 9
Energy efficiency class (Neodul LB PP)		B	C
Standing loss (Neodul LB PP)	[W]	80	117

Tank dimensions		NADO 500/300v1
Tank diameter	\varnothing d	650
Total tank height	L	1821
Tilting height	L _k	1841
Tank height	H	1691
Z/T circuit socket	B	245
Z/T circuit socket	C	1524
TJ 6/4" heating unit socket	E	484
Sensor pocket socket	F	584
Sensor pocket socket	G	1036
Sensor pocket socket	I	1532
Flange socket	J	327

Tank dimensions		NADO 750/250v1
Tank diameter	\varnothing d	750
Total tank height	L	2017
Tilting height	L _k	2040
Tank height	H	1895
Discharging connection	A	90
Z/T circuit socket	B	268
Z/T circuit socket	C	615
Z/T circuit socket	E	821
Z/T circuit socket	F	1643
Sensor pocket socket	G	268
Sensor pocket socket	I	615
Sensor pocket socket	J	1060
Sensor pocket socket	K	1553
TJ 6/4" heating unit socket	M	465
TJ 6/4" heating unit socket	N	525
TJ 6/4" heating unit socket	O	585
Flange socket	P	342

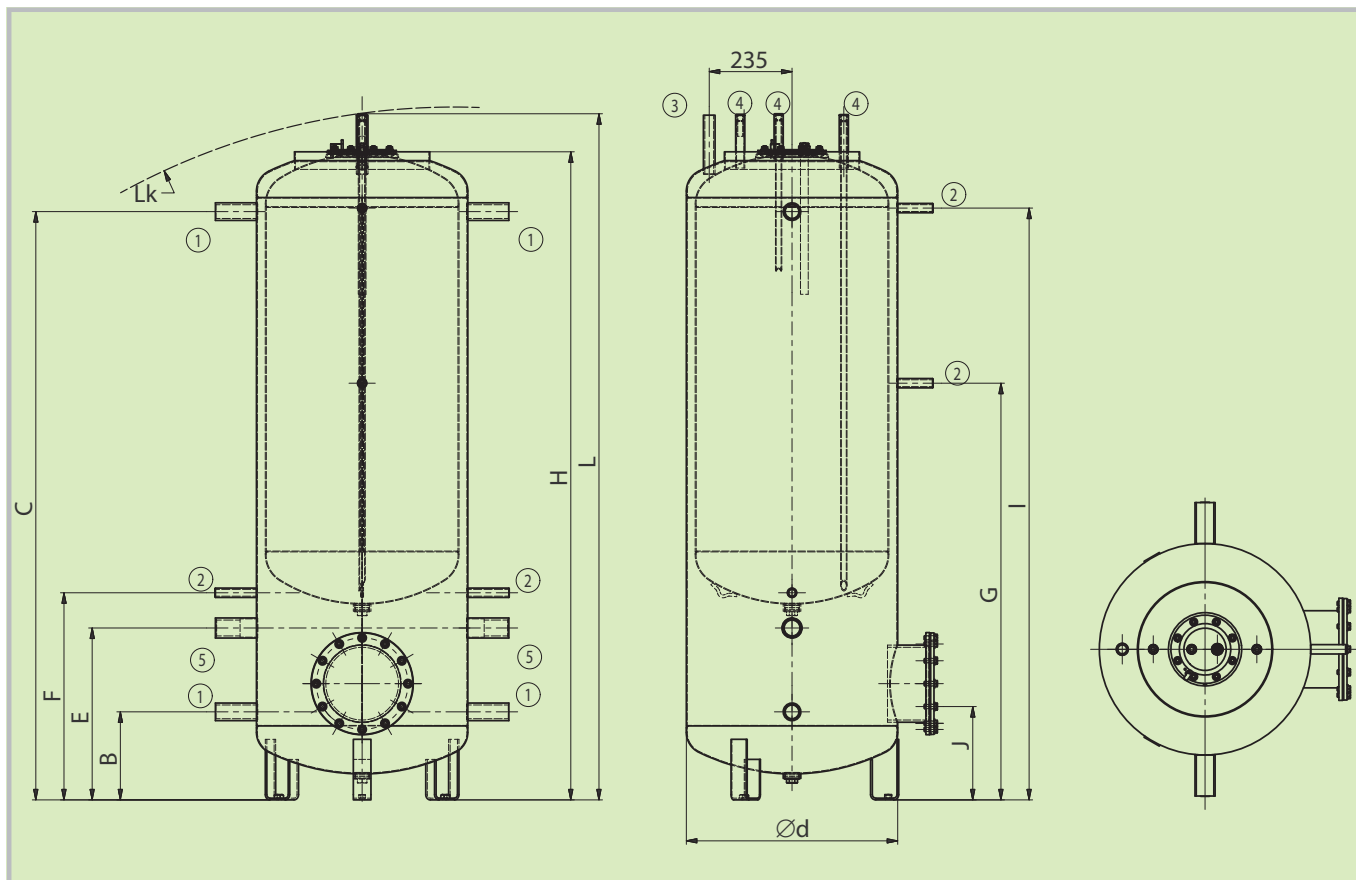

NADO 500/300v1

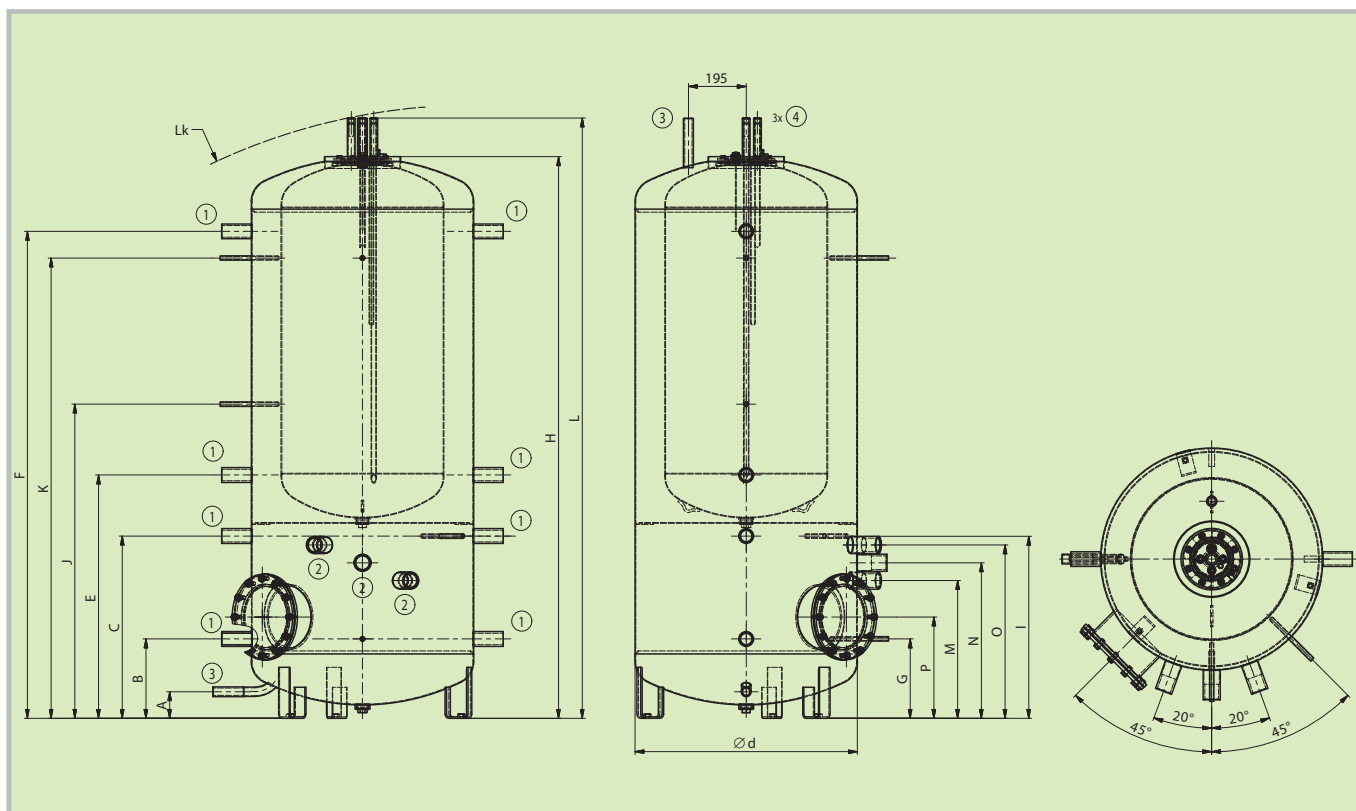

NADO 750/250v1

Storage tank NADO v2



- Types: 500, 750, 1000 l
- Inner HW storage tank in a volume of 140 l
- The tank is supplied without insulation
- Modern Neodul insulation can be ordered
- Suitable as a storage tank for heating systems with solid fuel boilers and solar systems
- The TPK 210/12 heating unit can be mounted into the flange
- The TJ 6/4" heating unit can be mounted for tanks with inner storage tank in a volume of 140 l



Socket dimensions	NADO 500/140v2	NADO 750/140v2	NADO 1000/140v2
Socket 1 – female thread		1 1/4"	
Socket 2 – female thread		1/2"	
Socket 3 – male thread		1"	
Socket 4 – male thread		3/4"	
Socket 5 – female thread		1 1/2"	

Technical parameters		NADO 500/140v2	NADO 750/140v2	NADO 1000/140v2
Order number		121380391	121680391	121580391
Heating water volume in tank	[l]	475	772	999
Volume of storage tank for HW heating	[l]		140	
Weight	[kg]	143	168	180
Max. operating temperature / pressure in tank	[°C] / [bar]		90 / 3	
Max. operating temperature / pressure in HW storage tank	[°C] / [bar]		90 / 6	
Heat transfer surface of HW storage tank	[m ²]		1,43	
Max. operating temperature / pressure in exchanger	[°C] / [bar]		110 / 10	
Heat transfer surface of exchanger	[m ²]		1,5	
Exchanger volume	[l]		10,5	
Capacity of hot water 40 °C at storage tank temperature 53 °C and inlet water 15 °C / HW flow rate*	[l] / [l·min ⁻¹]	260 / 5	490 / 5	750 / 5
Capacity of hot water 40 °C at storage tank temperature 80 °C and inlet water 15 °C / HW flow rate*	[l] / [l·min ⁻¹]	650 / 5	1170 / 5	1450 / 5
Insulation thickness (Neodul LB PP)	[mm]		80	
Heat conductivity of insulation (Neodul LB PP)	[W·m ⁻¹ ·K ⁻¹]		0,032	
Insulation order number (Neodul LB PP)		6231902	6231904	6231905
Max. number × output of TPK 210-12	[ks] × [kW]	1 × 6		1 × 12
Max. number × output of TJ 6/4"	[ks] × [kW]		1 × 9	
Exchanger volume flow rate	[m ³ ·h ⁻¹]		0,3	
Energy efficiency class (Neodul LB PP)		B		C
Standing loss (Neodul LB PP)	[W]	79	116	128

Tank dimensions		NADO 500/140v2	NADO 750/140v2	NADO 1000/140v2
Tank diameter	∅ d	600	750	850
Total tank height	L	1965	2022	2035
Tilting height	L _K	1985	2035	2080
Discharging connection	A	90	90	90
Z/T circuit socket	B	258	272	292
Z/T circuit socket	C	946	960	980
Z/T circuit socket	E	1632	1646	1666
Sensor pocket socket	F	493	508	527
Sensor pocket socket	G	1542	1556	1576
Tank height	H	1835	1895	1905
TJ 6/4" heating unit socket	I	925	940	960
Heat exchanger socket	J	348	368	382
Heat exchanger socket	K	876	896	910
Flange socket	M	341	357	375



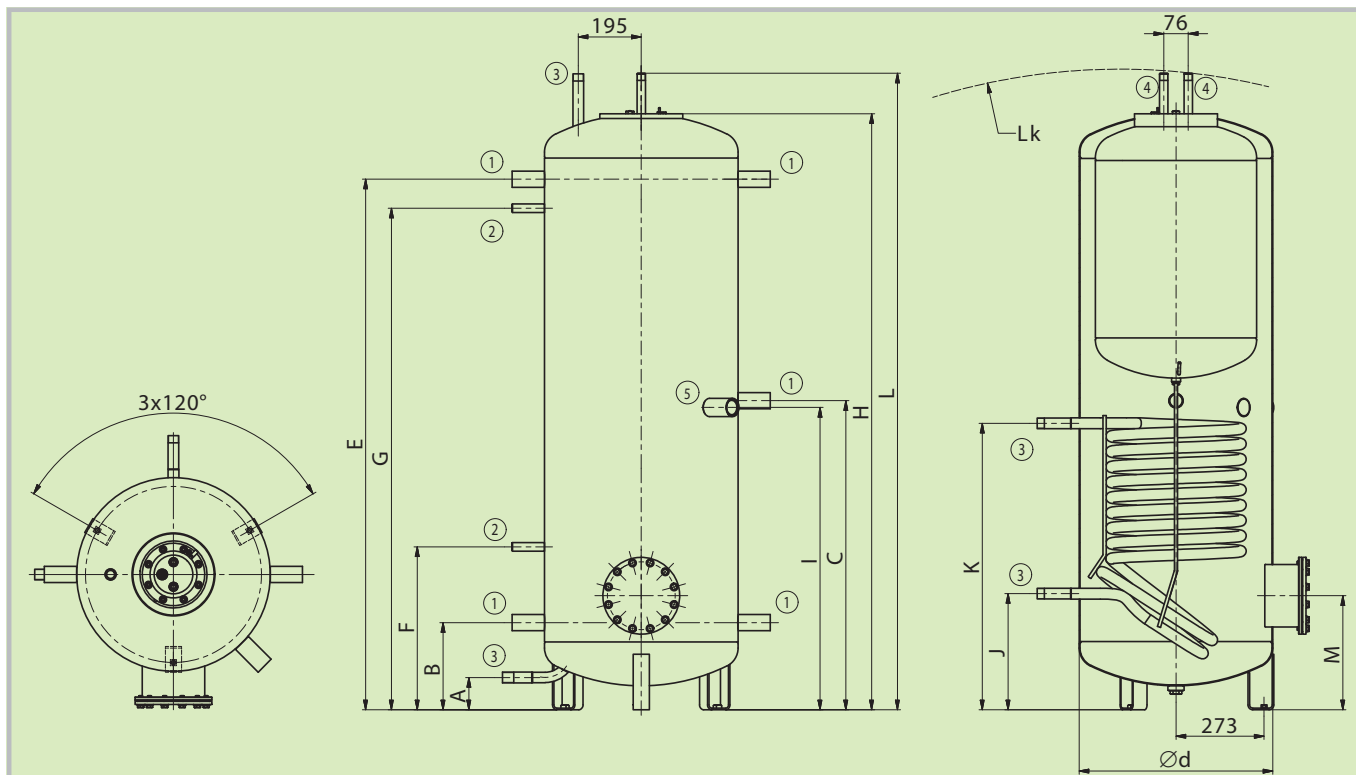

NADO 500/140v2

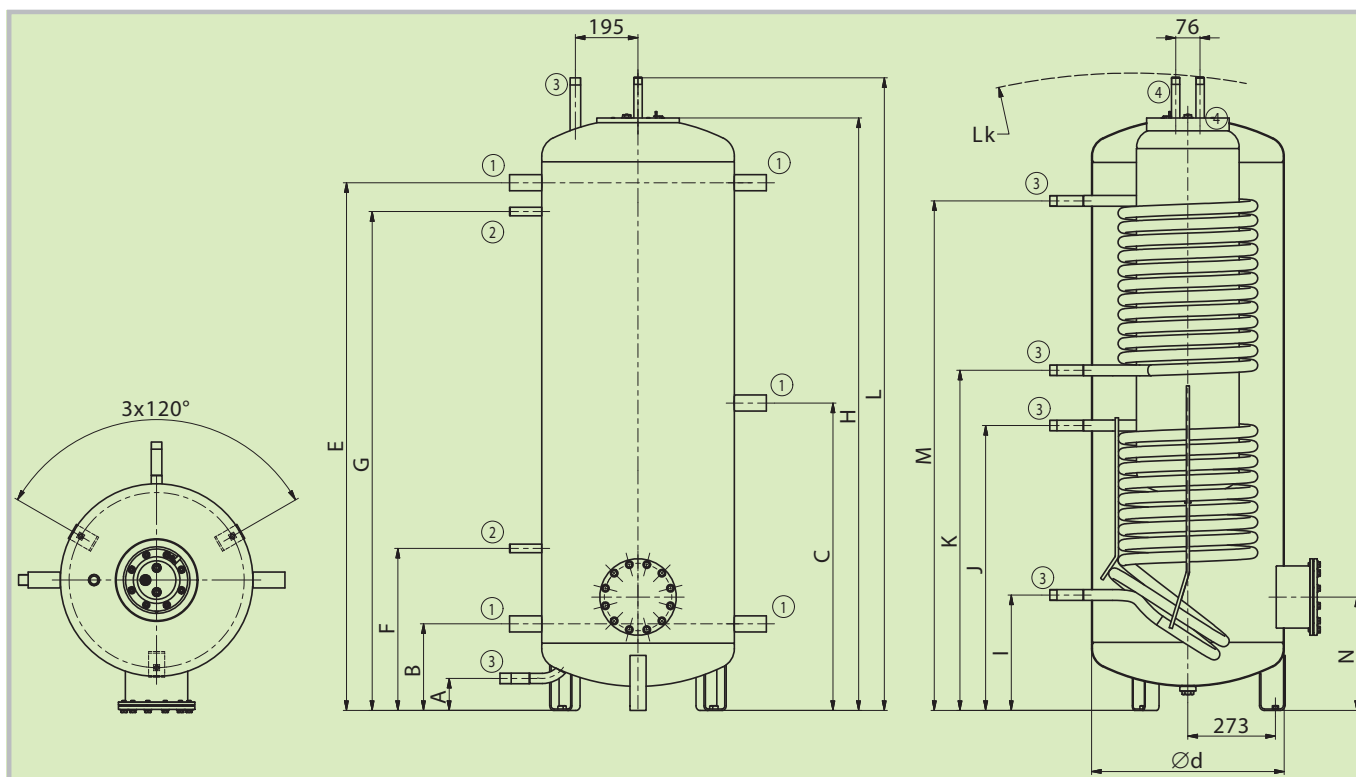

NADO 500v3



Storage tank NADO v3



- Types: 500, 750, 1000 l
- Inner HW storage tank in a volume of 100 l
- The tank is supplied without insulation
- Modern Neodul insulation can be ordered
- Suitable as an storage tank for heating systems with solid fuel boilers and solar systems
- The TPK 210/12 heating unit can be mounted into the flange



Socket dimensions	NADO 500/100v3	NADO 750/100v3	NADO 1000/100v3
Socket 1 – female thread		1 1/4"	
Socket 2 – female thread		1/2"	
Socket 3 – male thread		1"	
Socket 4 – female thread		3/4"	

Technical parameters		NADO 500/100v3	NADO 750/100v3	NADO 1000/100v3
Order number		121380388	121680388	121580388
Heating water volume in tank	[l]	475	772	999
Volume of storage tank for HW heating	[l]		92	
Weight	[kg]	168	195	202
Max. operating temperature / pressure in tank	[°C] / [bar]		90 / 3	
Max. operating temperature / pressure in HW storage tank	[°C] / [bar]		90 / 6	
Heat transfer surface of HW storage tank	[m ²]		1,25	
Max. operating temperature / pressure in exchanger	[°C] / [bar]		110 / 10	
Heat transfer surface of exchanger (top / bottom)	[m ²]		1,5 / 1,5	
Exchanger volume (top / bottom)	[l]		10,5 / 10,5	
Capacity of hot water 40 °C at storage tank temperature 53 °C and inlet water 15 °C / HW flow rate*	[l] / [l·min ⁻¹]	260 / 5	490 / 5	750 / 5
Capacity of hot water 40 °C at storage tank temperature 80 °C and inlet water 15 °C / HW flow rate*	[l] / [l·min ⁻¹]	650 / 5	1170 / 5	1450 / 5
Insulation thickness (Neodul LB PP)	[mm]		80	
Heat conductivity of insulation (Neodul LB PP)	[W·m ⁻¹ ·K ⁻¹]		0,032	
Insulation order number (Neodul LB PP)		6231902	6231904	6231905
Max. number × output of TPK 210-12	[ks] × [kW]	1 × 6		1 × 12
Exchanger volume flow rate	[m ³ ·h ⁻¹]		0,3	
Energy efficiency class (Neodul LB PP)		B		C
Standing loss (Neodul LB PP)	[W]	80	117	130

Tank dimensions		NADO 500/100v3	NADO 750/100v3	NADO 1000/100v3
Tank diameter	∅ d	600	750	850
Total tank height	L	1965	2022	2035
Tilting height	L _k	1985	2035	2080
Tank height	H	1835	1895	1905
Discharging connection	A	90	90	90
Z/T circuit socket	B	258	272	292
Z/T circuit socket	C	946	960	980
Z/T circuit socket	E	1632	1646	1666
Sensor pocket socket	F	493	508	527
Sensor pocket socket	G	1542	1556	1576
Heat exchanger socket	I	348	368	382
Heat exchanger socket	J	876	896	910
Heat exchanger socket	K	1050	1061	1084
Heat exchanger socket	M	1578	1589	1612
Flange socket	O	341	357	375

Storage tank NADO v6



- Types: 300, 500, 750, 1000 l
- Heating by HW flow in a stainless steel exchanger with an above-average heat transfer surface
- The tank is available with insulation in a volume of 300 l and without insulation in volumes of 500, 750, and 1000 l
- Modern Neodul insulation can be ordered
- Various heat sources can be connected such as biomass, coal, gas and electric boilers, heat pumps and solar collectors
- The TJ 6/4" electric cartridges can be mounted into sockets no. 4



NADO 300v6

NADO 500, 750, 1000v6

Socket dimensions	NADO 300/20v6	NADO 500/25v6	NADO 750/35v6	NADO 1000/45v6
Socket 1 – female thread			1¼"	
Socket 2 – male thread			1"	
Socket 3 – female thread			½"	
Socket 4 – female thread			1½"	
Socket 5 – male thread			1¼"	

Technical parameters		NADO 300/20v6	NADO 500/25v6	NADO 750/35v6	NADO 1000/45v6
Order number		121080398	121380350	121680350	121580350
Heating water volume in tank	[l]	320	475	772	999
Exchanger volume pro ohřev TV	[l]	20	23	32	37
Weight	[kg]	106	134	165	197
Max. operating temperature / pressure in tank	[°C] / [bar]	90 / 3			
Max. operating temperature / pressure in exchanger TV	[°C] / [bar]	90 / 6			
Max. operating temperature / pressure in heat exchanger	[°C] / [bar]	110 / 10			
Heat transfer surface of exchanger TV	[m ²]	4,5	6,25	8,5	10
HW exchanger volume flow rate	[m ³ ·h ⁻¹]	0,6			
Heat transfer surface of heat exchanger (top / bottom)	[m ²]	- / 1,6	- / 2,2	- / 2,2	- / 3,3
Heat exchanger volume (top / bottom)	[l]	- / 12	- / 18	- / 18	- / 25
Capacity of hot water 40 °C at storage tank temperature 53 °C and inlet water 15 °C / HW flow rate*	[l] / [l·min ⁻¹]	210 / 10	260 / 10	490 / 10	750 / 10
Capacity of hot water 40 °C at storage tank temperature 80 °C and inlet water 15 °C / HW flow rate*	[l] / [l·min ⁻¹]	520 / 10	650 / 10	1170 / 10	1450 / 10
Insulation thickness (Neodul LB PP)	[mm]	60	80		
Heat conductivity of insulation (Neodul LB PP)	[W·m ⁻¹ ·K ⁻¹]	0,032			
Insulation order number (Neodul LB PP)		tank component	6231957	6231958	6231959
Max. num. × out. of TPK TJ 6/4" h. unit with extended cooling section	[ks] × [kW]	2 × 4,5	2 × 6		
Energy efficiency class (Neodul LB PP)		C			
Standing loss (Neodul LB PP)	[W]	97	91	114	148

Tank dimensions		NADO 300/20v6	NADO 500/25v6	NADO 750/35v6	NADO 1000/45v6
Tank diameter	∅ d	550	600	750	850
Tank diameter with insulation	∅ D	670	-	-	-
Total tank height	L	1610	1965	2022	2035
Tilting height	L _k	1820	1985	2035	2080
Tank height	H	1658	1835	1895	1905
Discharging connection	A	80	90	90	90
Z/T circuit socket	B	238	258	272	292
Z/T circuit socket	C	-	946	1008	1030
Z/T circuit socket	E	1438	1654	1670	1693
HW socket – inlet	F	1298	304	310	373
HW socket – outlet	G	1438	1604	1670	1693
Solar exchanger socket – outlet	I	228	238	260	273
Solar exchanger socket – inlet	J	756	898	874	973
Sensor pocket socket	K	458	383	405	459
Sensor pocket socket	M	-	751	732	751
Sensor pocket socket	N	-	1273	1209	1209
Sensor pocket socket	O	1348	1654	1685	1667
TJ 6/4" heating unit socket	P	816	985	1007	1031
TJ 6/4" heating unit socket	R	100	225	290	340



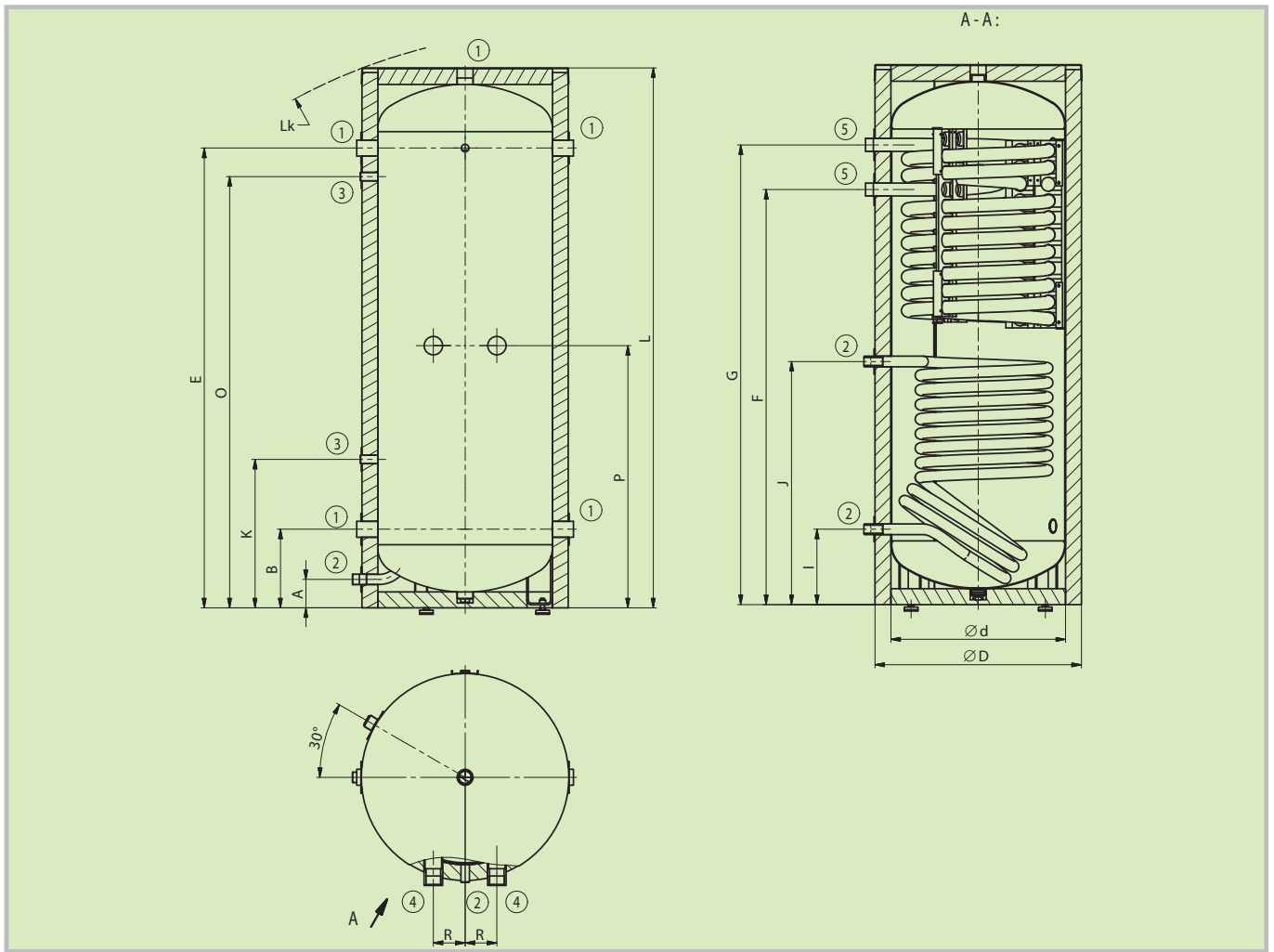

NADO 300v6

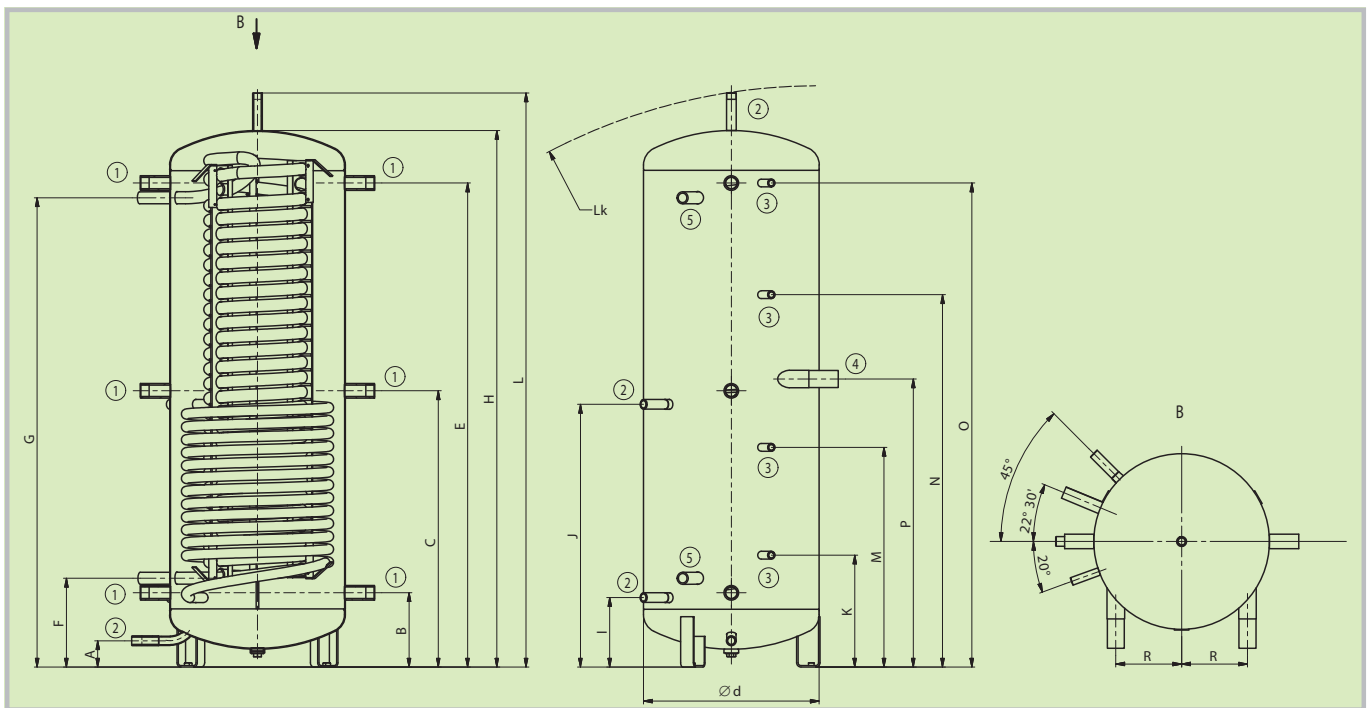

NADO 500, 750, 1000v6

Storage tank NADO v7



- Types: 500, 750, 1000 l
- HW heating in inner storage tank 200 l
- The tank is supplied without insulation
- Modern Neodul insulation can be ordered
- Various heat sources can be connected such as biomass, coal, gas and electric boilers, heat pumps and solar collectors
- The TJ 6/4" heating unit can be mounted into sockets no. 5



Socket dimensions	NADO 500/200v7	NADO 750/200v7	NADO 1000/200v7
Socket 1 – female thread		1 1/4"	
Socket 2 – female thread		1/2"	
Socket 3 – male thread		1"	
Socket 4 – male thread		3/4"	
Socket 5 – female thread	–		1 1/2"

Technical parameters		NADO 500/200v7	NADO 750/200v7	NADO 1000/200v7
Order number		121380373	121880354	121780354
Heating water volume in tank	[l]	475	772	999
Volume of storage tank for HW heating	[l]		233	
Weight	[kg]	175	212	243
Max. operating temperature / pressure in tank	[°C] / [bar]		90 / 3	
Max. operating temperature / pressure in exchanger TV	[°C] / [bar]		90 / 6	
Max. operating temperature / pressure in heat exchanger	[°C] / [bar]		110 / 10	
Heat transfer surface of HW storage tank	[m ²]		2,29	
Exchanger volume flow rate	[m ³ ·h ⁻¹]		0,6	
Heat transfer surface of heat exchanger	[m ²]	2,5	3,3	3,3
Heat exchanger volume	[l]	18	25	25
Capacity of hot water 40 °C at storage tank temperature 53 °C and inlet water 15 °C / HW flow rate*	[l] / [l·min ⁻¹]	260 / 10	490 / 10	750 / 10
Capacity of hot water 40 °C at storage tank temperature 80 °C and inlet water 15 °C / HW flow rate*	[l] / [l·min ⁻¹]	650 / 10	1170 / 10	1450 / 10
Insulation thickness (Neodul LB PP)	[mm]		80	
Heat conductivity of insulation (Neodul LB PP)	[W·m ⁻¹ ·K ⁻¹]		0,032	
Insulation order number (Neodul LB PP)		6231923	6231956	6231948
Max. num. × out. of TPK TJ 6/4" h. unit with extended cooling section	[ks] × [kW]	–		2 × 6
Energy efficiency class (Neodul LB PP)		B		C
Standing loss (Neodul LB PP)	[W]	76	113	126

Tank dimensions		NADO 500/200v7	NADO 750/200v7	NADO 1000/200v7
Tank diameter	∅ d	600	790	790
Total tank height	L	1965	1945	2245
Tilting height	L _k	1985	1985	2310
Discharging connection	A	132	152	152
Z/T circuit socket	B	239	254	254
Z/T circuit socket	C	564	580	580
Z/T circuit socket	E	891	906	906
Z/T circuit socket	F	1216	1232	1232
Z/T circuit socket	G	–	–	1558
Z/T circuit socket	I	1609	1604	1904
Tank height	H	1835	1815	2115
Sensor pocket socket	J	467	464	464
Sensor pocket socket	K	680	684	684
Sensor pocket socket	M	1089	1104	1104
Sensor pocket socket	N	–	–	1404
Sensor pocket socket	O	1669	1604	1894
Solar exchanger socket – outlet	P	229	244	244
Solar exchanger socket – inlet	R	1009	904	904
TJ 6/4" heating unit socket	S	–	1069	1069



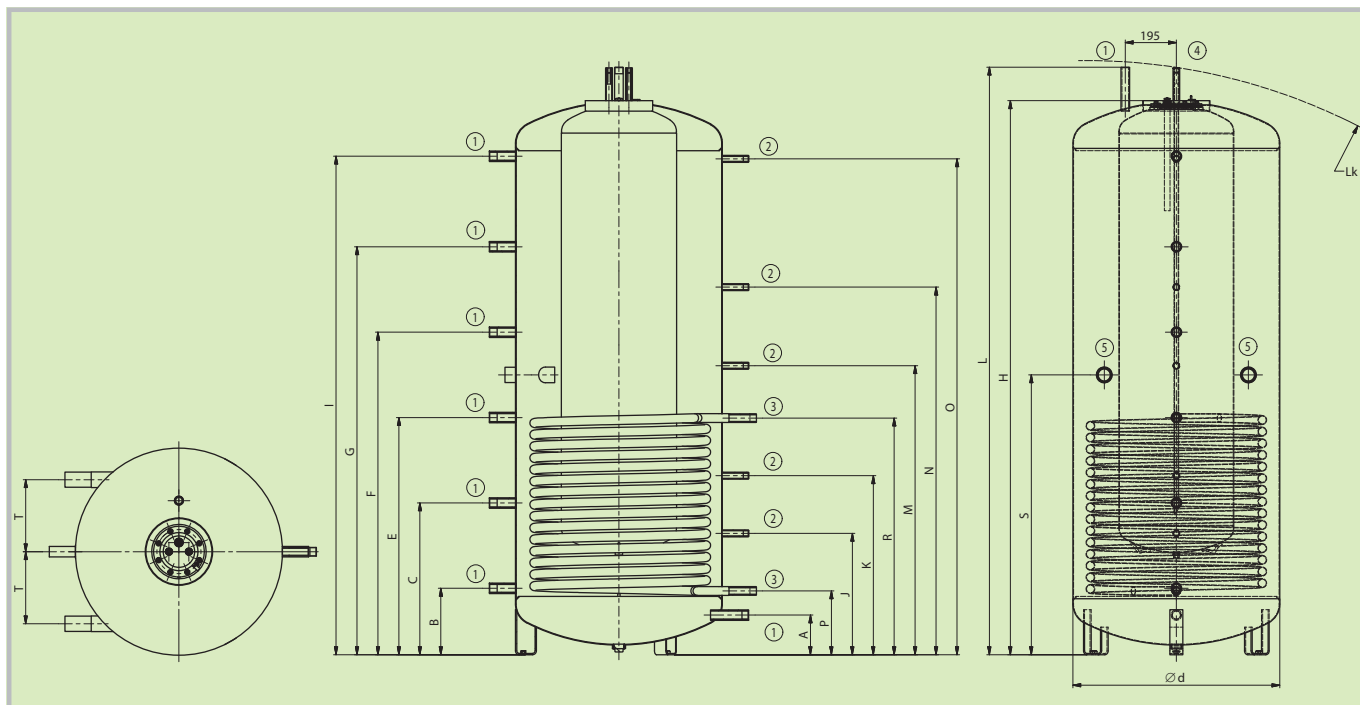

NADO 1000/200 v7

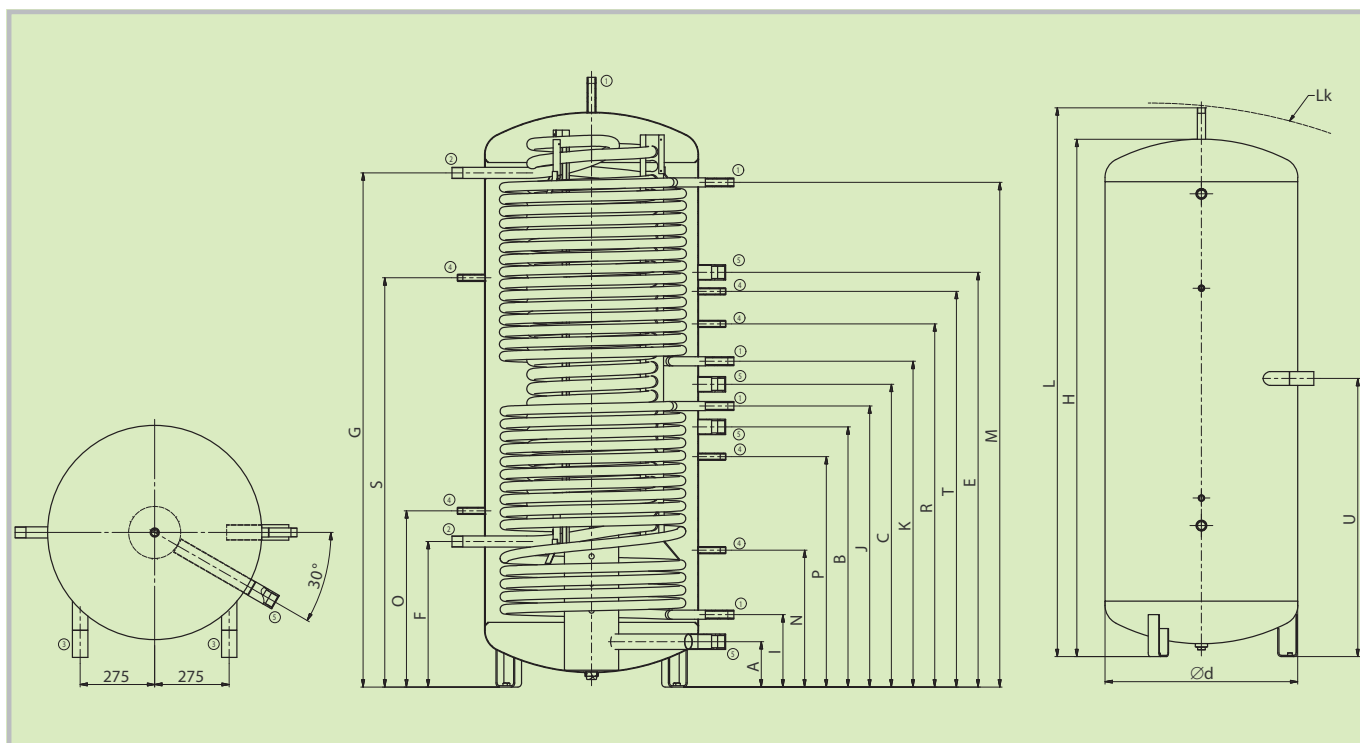

NADO 800/35 v9

Storage tank NADO v9



- Types: 800, 1000 l
- Heating by HW flow in a stainless steel exchanger with an above-average heat transfer surface
- The tank is supplied without insulation
- Modern Neodul insulation can be ordered
- Various heat sources can be connected such as biomass, coal, gas and electric boilers, heat pumps and solar collectors
- The TJ 6/4" heating unit can be mounted into sockets no. 3

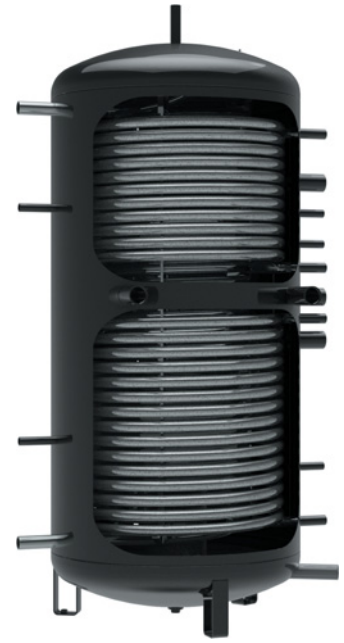

Socket dimensions	NADO 800/35v9	NADO 1000/35v9
Socket 1 – male thread		1"
Socket 2 – male thread		1 1/4"
Socket 3 – female thread		1 1/2"
Socket 4 – female thread		1/2"
Socket 5 – female thread		1 1/2"

Technical parameters		NADO 800/35v9	NADO 1000/35v9
Order number		121880333	121780333
Heating water volume in tank	[l]	820	999
Volume of storage tank for HW heating	[l]	32	32
Weight	[kg]	224	275
Max. operating temperature / pressure in tank	[°C] / [bar]		90 / 3
Max. operating temperature / pressure in exchanger TV	[°C] / [bar]		90 / 6
Max. operating temperature / pressure in heat exchanger	[°C] / [bar]		110 / 10
Heat transfer surface of exchanger TV	[m ²]		8,5
HW exchanger volume flow rate	[m ³ ·h ⁻¹]		0,6
Heat transfer surface of heat exchanger (top / bottom)	[m ²]	2,2 / 3,3	3,3 / 3,3
Heat exchanger volume (top / bottom)	[l]	18 / 25	25 / 25
Capacity of hot water 40 °C at storage tank temperature 53 °C and inlet water 15 °C / HW flow rate*	[l] / [l·min ⁻¹]	620 / 10	750 / 10
Capacity of hot water 40 °C at storage tank temperature 80 °C and inlet water 15 °C / HW flow rate*	[l] / [l·min ⁻¹]	1287 / 10	1450 / 10
Insulation thickness (Neodul LB PP)	[mm]		80
Heat conductivity of insulation (Neodul LB PP)	[W·m ⁻¹ ·K ⁻¹]		0,032
Insulation order number (Neodul LB PP)		6231992	6231993
Max. number × output of TPK TJ 6/4" heating unit with extended cooling section	[ks] × [kW]		2 × 6
Energy efficiency class (Neodul LB PP)			C
Standing loss (Neodul LB PP)	[W]	118	138

Tank dimensions		NADO 800/35v9	NADO 1000/35v9
Tank diameter	∅ d	790	790
Total tank height	L	1945	2245
Tilting height	L _k	1985	2280
Stratification column socket	A	156	156
Z/T circuit socket	B	879	952
Z/T circuit socket	C	1019	1109
Z/T circuit socket	E	1392	1552
HW socket – inlet	F	259	529
HW socket – outlet	G	1599	1889
Tank height	H	1815	2115
Solar exchanger socket – outlet	I	289	259
Solar exchanger socket – inlet	J	949	1029
Upper exchanger socket – outlet	K	1115	1194
Upper exchanger socket – inlet	M	1552	1854
Sensor pocket socket	N	487	497
Sensor pocket socket	O	572	842
Sensor pocket socket	P	–	1209
Sensor pocket socket	R	1192	1332
Sensor pocket socket	S	1292	1502
Sensor pocket socket	T	1292	1452
TJ 6/4" heating unit socket	U	1019	1132

Storage tank UKV NIBE



- Types: 300, 500 l
- The tank is supplied with non-detachable insulation
- Suitable as an equalization tank for heating systems with heat pumps
- The TJ 6/4" heating unit can be mounted into sockets



Socket dimensions	NIBE UKV 300	NIBE UKV 500
Socket 1	1¼" female thread	1½" female thread
Socket 2	1½" female thread	1" male thread
Socket 3	½" female thread	½" female thread
Socket 4	1" male thread	

Technical parameters		NIBE UKV 300	NIBE UKV 500
Order number		121080371	121380337
Heating water volume in tank	[l]	316	470
Weight	[kg]	79	103
Max. operating temperature / pressure in tank	[°C] / [bar]		90 / 6
Insulation thickness (Polyurethane)	[mm]		50
Heat conductivity of insulation (Polyurethane)	[W·m ⁻¹ ·K ⁻¹]		0,022
Max. number × output of TJ 6/4"	[ks] × [kW]	2 × 7,5	2 × 9
Energy efficiency class (Polyurethane)		C	C
Standing loss (Polyurethane)	[W]	79	96

Tank dimensions		NIBE UKV 300	NIBE UKV 500
Tank diameter	∅ d	550	600
Tank diameter with insulation	∅ D	650	700
Total tank height	L	1580	1937
Tilting height	L _k	1610	1980
Z/T circuit socket	A	230	270
Z/T circuit socket	B	1300	1400
Z/T circuit socket	C	–	1650
Heating unit socket	E	1030	1400
Heating unit socket	F	1180	1550
Sensor pocket socket	G	230	270
Sensor pocket socket	I	766	960
Sensor pocket socket	J	1300	1650

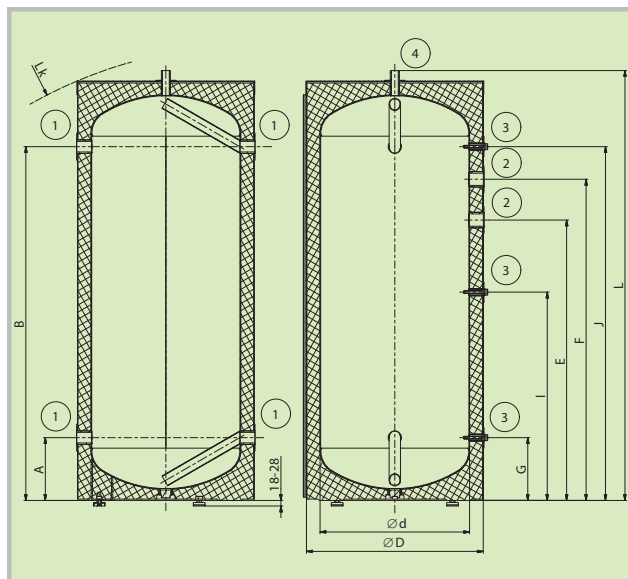

UKV 300

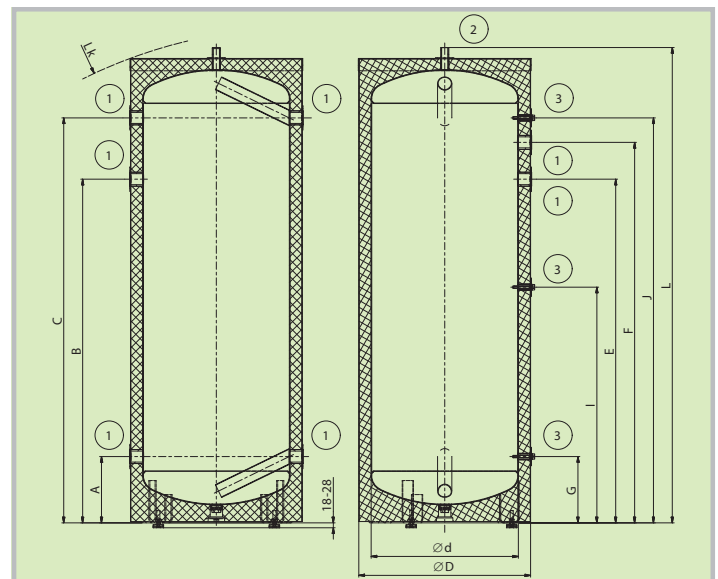

UKV 500

Heat insulation of the utmost quality

Neodul LB PP heat insulation

- The delivery includes a top cover, flange covers and hole caps
- The NAD 50, 100, 250 v1 and UKV 300, 500 tanks are supplied with polyurethane insulation

- Standard delivery for larger tanks
- The first and only category B series insulation on the market
- Standard thickness of insulation is 80 mm
- Example of heat loss for 500 l tank: 1.9 kWh/24 h with an insulation thickness of 100 mm

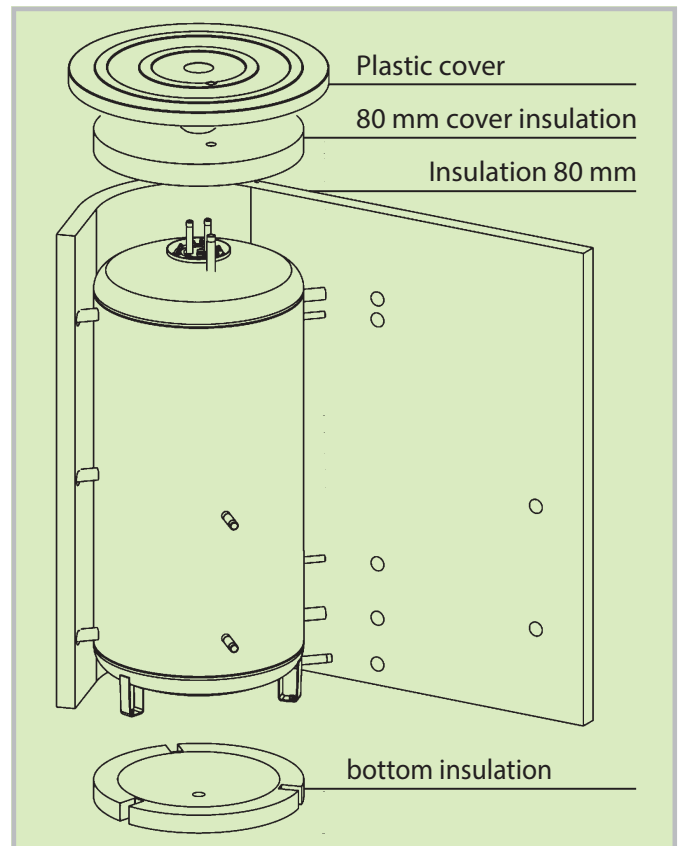

Neodul LB PP

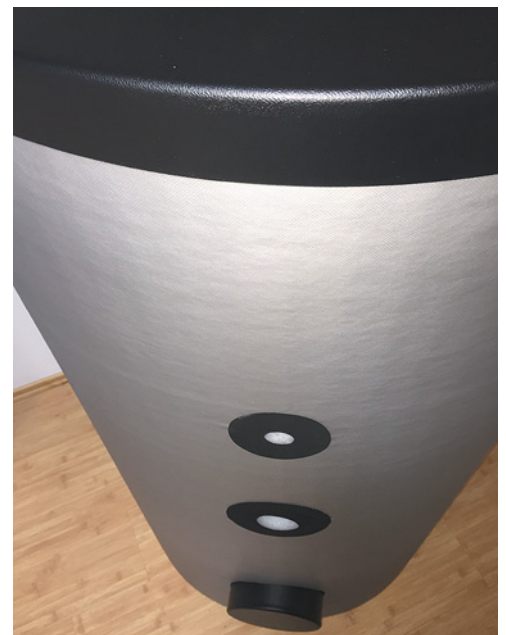
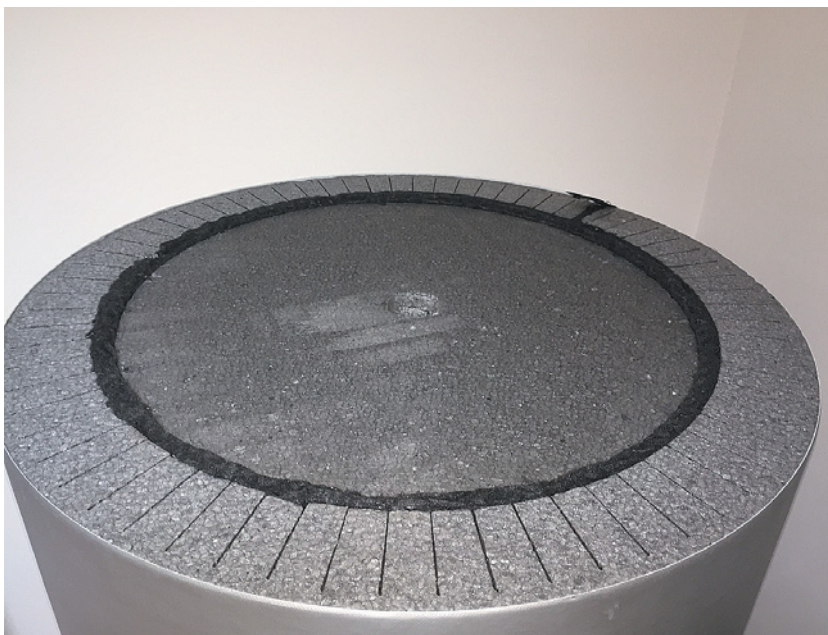

Original parts from Dražice

- 24 month warranty period
- Reliability and high quality
- Guarantee of functionality and safety
- Guaranteed long life
- Identical components used in manufacturing
- Easy availability throughout the Czech Republic

Anode with external power supply

- Used for protection of inner enamel storage tanks and extends their life span
- Usable up to a volume of 300 l
- Maintenance free, wear proof
- To order

Diameter	2 mm
Length	200 mm
Coat length	100 mm

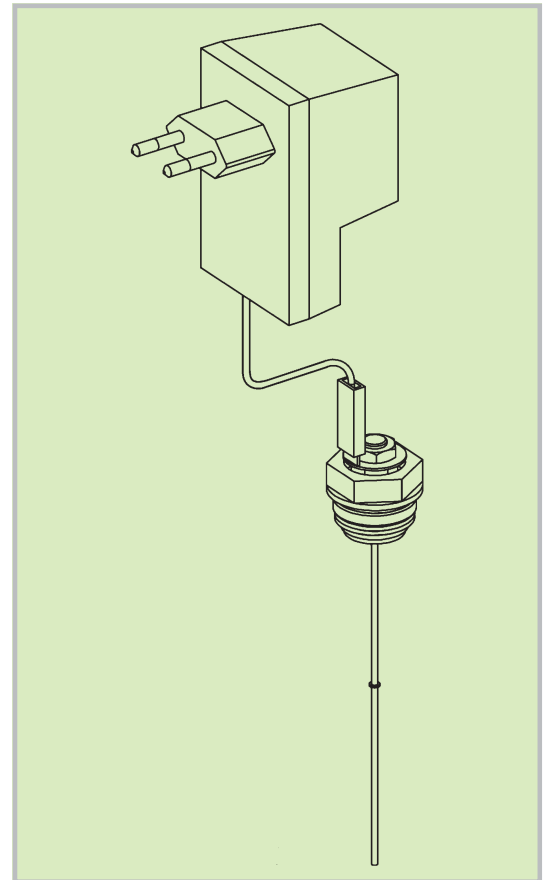

Flanged heating units with ceramic body TPK

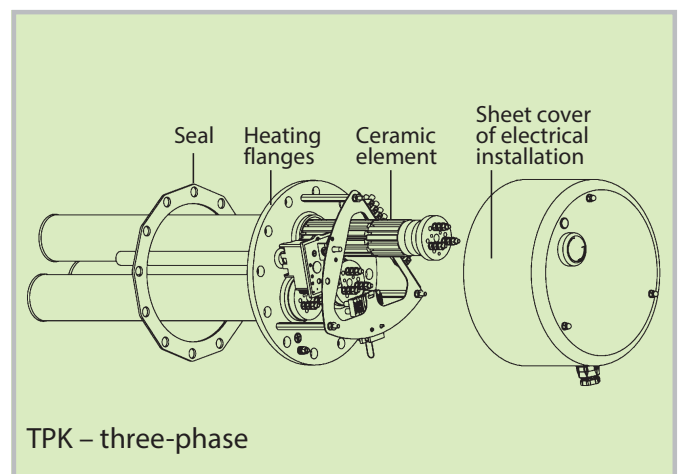
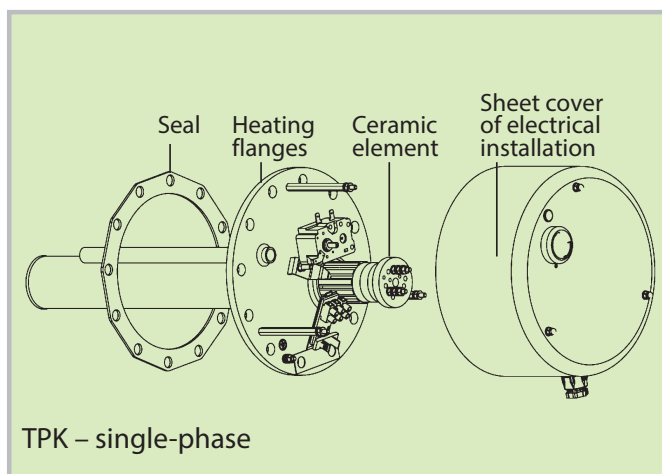

Original parts from Dražice

Screw-type electrical heating units of the TJ series

TJ G 6/4"		TJ 6/4"-2	TJ 6/4"-2,5	TJ 6/4"-3,3	TJ 6/4"-3,75	TJ 6/4"-4,5	TJ 6/4"-6	TJ 6/4"-7,5	TJ 6/4"-9
Order number L/L1		-/ 2110030	-/ 2110031	2110001/ -	-/ 2110033	-/ 2110034	-/ 2110035	2110006/ 2110036	2110007/ 2110037
Power consumption	[kW]	2	2,5	3,3	3,75	4,5	6	7,5	9
Weight	[kg]	1,2	1,3	1,7	2	2	2	2 / 2,3	2 / 2,3
Overall dimensions (∅ × L/L1)	[mm]	126 × - / 525	126 × - / 550	126 × 470 / -	126 × - / 595	126 × - / 645	126 × - / 665	126 × 720 / 830	126 × 750 / 865
Extension length L/L1	[mm]	- / 380	- / 405	325 / -	- / 450	- / 500	- / 520	575 / 685	605 / 720
Electrical connection		1/N/PE ~ 230V/50Hz	1/N/PE ~ 230V/50Hz	3/N/PE ~ 400V/50Hz, ⤴	3/N/PE ~ 400V/50Hz, ⤴	3/N/PE ~ 400V/50Hz, ⤴	3/N/PE ~ 400V/50Hz, ⤴	3/N/PE ~ 400V/50Hz, ⤴	3/N/PE ~ 400V/50Hz, ⤴
Recomm. circuit breaker value	[A]	16	16	3 × 10	3 × 10	3 × 10	3 × 16	3 × 16	3 × 20
Degree of protection		IP44							
Scale of set temperature	[°C]	5-74							
Heat. time approx. 150110-60°C	[h]	4,5	4,0	2,7	2,3	2,0	1,5	1,3	1,0
Heat. time approx. 150135-60°C	[h]	2,2	2,0	1,5	1,2	1,0	0,7	0,6	0,5

Extension lengths are in a tolerance of ± 10 mm.

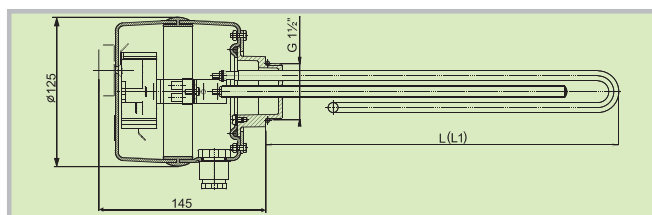

Flanged electrical heating units of the R, SE series

R, SE		REU 18-2,5	RDU 18-2,5	RDU 18-3	RDU 18-3,8	RDU 18-5	RDU 18-6	RDU 18-7,5	RDU 18-10	RSW 18-12	RSW 18-15	SE 377	SE 378
Order number		100541551	100541560	100541561	100541562	100541563	100541564	100541570	100541571	100541580	100541581	100541517	100541511
Power consumption	[kW]	2,5	2,5	3	3,8	5	6	7,5	10	12	15	8-11-16	9,5-12,7-19
Weight	[kg]	3	3,3	3,4	3,5	3,5	3,5	3,7	4	4	4,2	8	11,5
Overall dimensions (∅ × L)	[mm]	188 × 560											
Extension length	[mm]	450	450	450	450	450	450	450	450	530	630	610	740
Electrical connection		1/N/PE ~ 230V/ 50Hz	3/N/PE ~ 400V/ 50Hz, ⤴	3/N/PE ~ 400V/ 50Hz, ⤴	3/N/PE ~ 400V/ 50Hz, ⤴	3/N/PE ~ 400V/ 50Hz, ⤴	3/N/PE ~ 400V/ 50Hz, ⤴	3/N/PE ~ 400V/ 50Hz, ⤴	3/N/PE ~ 400V/ 50Hz, ⤴	3/N/PE ~ 400V/ 50Hz, ⤴	3/N/PE ~ 400V/ 50Hz, ⤴	3/N/PE ~ 400V/ 50Hz, ⤴	3/N/PE ~ 400V/ 50Hz, ⤴
Recomm. circuit breaker value	[A]	16	3 × 6	3 × 6	3 × 10	3 × 10	3 × 16	3 × 16	3 × 20	3 × 20	3 × 25	3 × 25	3 × 32
Degree of protection		IPX4											
Heat. time approx. 300110-60°C	[h]	8,0	8,0	6,0	5,0	4,0	3,0	2,5	2,0	1,5	1,3	2,0-2,0-1,3	2,0-1,5-1,0

Extension lengths are in a tolerance of ± 10 mm.



Flanged electrical heating units with ceramic body of the TPK series

TPK		TPK 150-8/2,2	TPK 168-8/2,2	TPK 210-12/2,2	TPK 210-12/3-6	TPK 210-12/6,6	TPK 210-12/5-9	TPK 210-12/8-12
Order number		2110409	2110055	2110053	2110050	2110410	2110051	2110052
Power consumption	[kW]	2,2	2,2	2,2	3-4-6	6,6	5-7-9	8-10-12
Weight	[kg]	4,2	4,2	6,6	12	13	13,6	14
Overall dimensions (∅ × L)	[mm]	185 × 510	219 × 515	245 × 564	245 × 564	245 × 564	245 × 674	245 × 674
Extension length	[mm]	400	400	440	440	440	550	550
Electrical connection		1/N/PE ~ 230V/50Hz	1/N/PE ~ 230V/50Hz	1/N/PE ~ 230V/50Hz	1/N/PE ~ 230V/50Hz, 3/N/PE ~ 400V/50Hz, ⤴	1/N/PE ~ 230V/50Hz, 3/N/PE ~ 400V/50Hz, ⤴	3/N/PE ~ 400V/50Hz, ⤴	3/N/PE ~ 400V/50Hz, ⤴
Recomm. circuit breaker value	[A]	16	16	16	20 / 3 × 16	20 / 3 × 16	3 × 20	3 × 25
Degree of protection		IP42						
Scale of set temperature	[°C]	5-74						

* – according to connection method

Extension lengths are in a tolerance of ± 10 mm.



Original parts from Dražice

Mounting options for flanged electrical heating units of the R, SE series

Type	REU 18-2,5	RDU 18-2,5	RDU 18-3	RDU 18-3,8	RDU 18-5	RDU 18-6	RDW 18-7,5	RDW 18-10	RSW 18-12	RSW 18-15
NAD 500 v1	●	●	●	●	●	●	●	●	●	–
NAD 750 v1	●	●	●	●	●	●	●	●	●	●
NAD 1000 v1	●	●	●	●	●	●	●	●	●	●
NAD 500 v3	●	●	●	●	●	●	●	●	●	–
NAD 750 v3	●	●	●	●	●	●	●	●	●	●
NAD 1000 v3	●	●	●	●	●	●	●	●	●	●
NAD 500 v4	●	●	●	●	●	●	●	●	–	–
NAD 750 v4	●	●	●	●	●	●	●	●	●	–
NAD 1000 v4	●	●	●	●	●	●	●	●	●	●
NAD 500 v5	●	●	●	●	●	●	●	●	–	–
NAD 750 v5	●	●	●	●	●	●	●	●	●	–
NAD 1000 v5	●	●	●	●	●	●	●	●	●	●
NADO 500/140 v1	●	●	●	●	●	●	●	●	●	–
NADO 750/140 v1	●	●	●	●	●	●	●	●	●	●
NADO 1000/140 v1	●	●	●	●	●	●	●	●	●	●
NADO 500/200 v1	●	●	●	●	●	●	●	●	●	–
NADO 750/200 v1	●	●	●	●	●	●	●	●	●	●
NADO 1000/200 v1	●	●	●	●	●	●	●	●	●	●
NADO 500/140 v2	●	●	●	●	●	●	●	●	–	–
NADO 750/140 v2	●	●	●	●	●	●	●	●	●	–
NADO 1000/140 v2	●	●	●	●	●	●	●	●	●	●
NADO 500/100 v3	●	●	●	●	●	●	●	●	–	–
NADO 750/100 v3	●	●	●	●	●	●	●	●	●	–
NADO 1000/100 v3	●	●	●	●	●	●	●	●	●	●

- can only be fitted with the 210/150 reduction flange
- cannot be fitted

Mounting options for flanged electrical heating units of the TPK series

Type	TPK 210-12/2,2 kW	TPK 210-12/3-6 kW	TPK 210-12/5-9 kW	TPK 210-12/8-12 kW
NAD 500 v1	▲	▲	▲	▲
NAD 750 v1	▲	▲	▲	▲
NAD 1000 v1	▲	▲	▲	▲
NAD 500 v3	▲	▲	▲	▲
NAD 750 v3	▲	▲	▲	▲
NAD 1000 v3	▲	▲	▲	▲
NAD 500 v4	▲	▲	–	–
NAD 750 v4	▲	▲	▲	▲
NAD 1000 v4	▲	▲	▲	▲
NAD 500 v5	▲	▲	–	–
NAD 750 v5	▲	▲	▲	▲
NAD 1000 v5	▲	▲	▲	▲
NADO 500/140 v1	▲	▲	▲	▲
NADO 750/140 v1	▲	▲	▲	▲
NADO 1000/140 v1	▲	▲	▲	▲
NADO 500/200 v1	▲	▲	▲	▲
NADO 750/200 v1	▲	▲	▲	▲
NADO 1000/200 v1	▲	▲	▲	▲
NADO 500/140 v2	▲	▲	–	–
NADO 750/140 v2	▲	▲	▲	▲
NADO 1000/140 v2	▲	▲	▲	▲
NADO 500/100 v3	▲	▲	–	–
NADO 750/100 v3	▲	▲	▲	▲
NADO 1000/100 v3	▲	▲	▲	▲

- ▲ can be fitted
- cannot be fitted

Original parts from Dražice

Mounting options for screw-type electrical heating units of the TJ series

Type	TJ 6/4" – 2*	TJ 6/4" – 2,5*	TJ 6/4" – 3,3	TJ 6/4" – 3,75*	TJ 6/4" – 4,5*	TJ 6/4" – 6*	TJ 6/4" – 7,5	TJ 6/4" – 7,5*	TJ 6/4" – 9	TJ 6/4" – 9*
NAD 50 v1	–	–	▲	–	–	–	–	–	–	–
NAD 100 v1	▲	▲	▲	▲	▲	▲	–	–	–	–
NAD 250 v1	▲	▲	▲	▲	▲	▲	–	–	–	–
NAD 500 v1	▲	▲	▲	▲	▲	▲	▲	–	▲	–
NAD 750 v1	▲	▲	▲	▲	▲	▲	▲	▲	▲	▲
NAD 1000 v1	▲	▲	▲	▲	▲	▲	▲	▲	▲	▲
NAD 500 v2	▲	▲	▲	▲	▲	▲	▲	–	▲	–
NAD 750 v2	▲	▲	▲	▲	▲	▲	▲	▲	▲	▲
NAD 1000 v2	▲	▲	▲	▲	▲	▲	▲	▲	▲	▲
NAD 300 v3	▲	▲	▲	▲	▲	▲	▲	–	▲	–
NAD 500 v3	▲	▲	▲	▲	▲	▲	▲	–	▲	–
NAD 750 v3	▲	▲	▲	▲	▲	▲	▲	▲	▲	▲
NAD 1000 v3	▲	▲	▲	▲	▲	▲	▲	▲	▲	▲
NAD 500 v4	▲	▲	▲	▲	▲	▲	▲	–	▲	–
NAD 750 v4	▲	▲	▲	▲	▲	▲	▲	▲	▲	▲
NAD 1000 v4	▲	▲	▲	▲	▲	▲	▲	▲	▲	▲
NAD 500 v5	▲	▲	▲	▲	▲	▲	▲	–	▲	–
NAD 750 v5	▲	▲	▲	▲	▲	▲	▲	▲	▲	▲
NAD 1000 v5	▲	▲	▲	▲	▲	▲	▲	▲	▲	▲
NADO 500/140 v1	▲	▲	▲	▲	▲	▲	▲	–	▲	–
NADO 750/140 v1	▲	▲	▲	▲	▲	▲	▲	▲	▲	▲
NADO 1000/140 v1	▲	▲	▲	▲	▲	▲	▲	▲	▲	▲
NADO 500/300 v1	▲	▲	▲	▲	▲	▲	▲	▲	▲	▲
NADO 750/250 v1	▲	▲	▲	▲	▲	▲	▲	▲	▲	▲
NADO 500/140 v2	▲	▲	▲	▲	▲	▲	▲	–	▲	–
NADO 750/140 v2	▲	▲	▲	▲	▲	▲	▲	▲	▲	▲
NADO 1000/140 v2	▲	▲	▲	▲	▲	▲	▲	▲	▲	▲
NADO 300/20 v6	▲	▲	–	▲	▲	▲	–	–	–	–
NADO 500/25 v6	▲	▲	–	▲	▲	▲	–	–	–	–
NADO 750/35 v6	▲	▲	–	▲	▲	▲	–	–	–	–
NADO 1000/45 v6	▲	▲	–	▲	▲	▲	–	–	–	–
NADO 500/200 v7	▲	▲	–	▲	▲	▲	–	–	–	–
NADO 750/200 v7	▲	▲	–	▲	▲	▲	–	–	–	–
NADO 1000/200 v7	▲	▲	–	▲	▲	▲	–	–	–	–
NADO 800/35 v9	▲	▲	–	▲	▲	▲	–	–	–	–
NADO 1000/35 v9	▲	▲	–	▲	▲	▲	–	–	–	–
UKV 300	▲	▲	▲	▲	▲	▲	▲	–	–	–
UKV 500	▲	▲	▲	▲	▲	▲	▲	–	▲	–

* TJ 6/4" with extended cold side

- ▲ can be fitted
- cannot be fitted

Company history

The founding of the future cooperative company dates back to 1900, when widow Marie Kyselová put a flour-mill into the company's property, thus establishing a producer cooperative called "Grain store, artistic cylinder mill and bakery" in Dražice nad Jizerou.

Between the years 1910 and 1917, with advice of engineer Karel Novák, professor at the Technical Faculty in Prague, the new management headed by Václav Čančík focused on a very perspective production and distribution of electric power. A hydroelectric power plant with two turbines with an output of 300 HP was built in 1910. In 1917, 69 villages with 8,111 consumers were connected to the Dražice power plant. The company got to its top in the second half of the 1920s; it employed 220 employees and owned 8 hydroelectric power plants situated on the Jizera river, a steam-electric power plant, two mills, and a distribution network to which 383 villages with 24,080 users were connected. The turnover in 1930 amounted to amazing three-quarters of billion Czechoslovak crowns.

In 1948, after the forced sale of the distribution networks and the subsequent nationalisation of a large portion of the cooperative's property, the company focused its attention on products and services for people with the specialization in households and sports. Eight years later, one of its programmes was the custom production of water heaters under the leadership of the former tradesman Mr. Křovák.

At the end of the 1980s, the Družstevní kombinát Dražice cooperative produced approximately 13,000 combined water heaters a year. After the political situation changed in 1989, the cooperative was divided to independent trading companies. One of those companies was also a private company called Družstevní závody Dražice – strojírna s.r.o., which took over the production of water heaters.

An intense development started between the years 1992 and 2003. The range of products got wider, technologies were modernized and production increased continuously. The fundamental modernization took place at the end of 1997 by building an enamelling line. The DZ Dražice company became the largest domestic seller of water heaters and in 1994 it started to extend its export; the company exports its products to 16 European countries. In 2003, the company produced 95,000 heaters. In 2004, a new hall was built as in preparation of the construction of a new enamel kiln. That kiln was then built in the summer of 2005 and allowed the company to increase the capacity of the enamel plant and to improve the enamelling process. In 2005, the range of products was extended with storage tanks and, at the end of the year, new types of OKHE square-type water heaters were prepared. In that year, the company made 115,000 water heaters and employed 210 employees.

In 2006, 100% of interest of the DZ Dražice – strojírna s.r.o. company were transferred to Swedish company NIBE Industrier AB, which became the sole owner of DZ Dražice. During the summer of 2007, the production was extended to two assembly lines and the capacity increased to 150,000 units per year. DZ Dražice also started to offer NIBE heat pumps, as well as NIBE solar systems and through-flow and stainless steel heaters. In the last years the company has focused on further extension of its range of products. In 2011, the company extended its products with a water heater with heat pump, a hybrid heater with the option of connecting to photovoltaic panels, an outdoor storage tank. Also, it introduced a heater with smart control and a number of functions (OKHE SMART). In September 2014, at the ForTherm exhibition it presented its new model OKHE SMART EVO 3 with the possibility of control using smart phones.

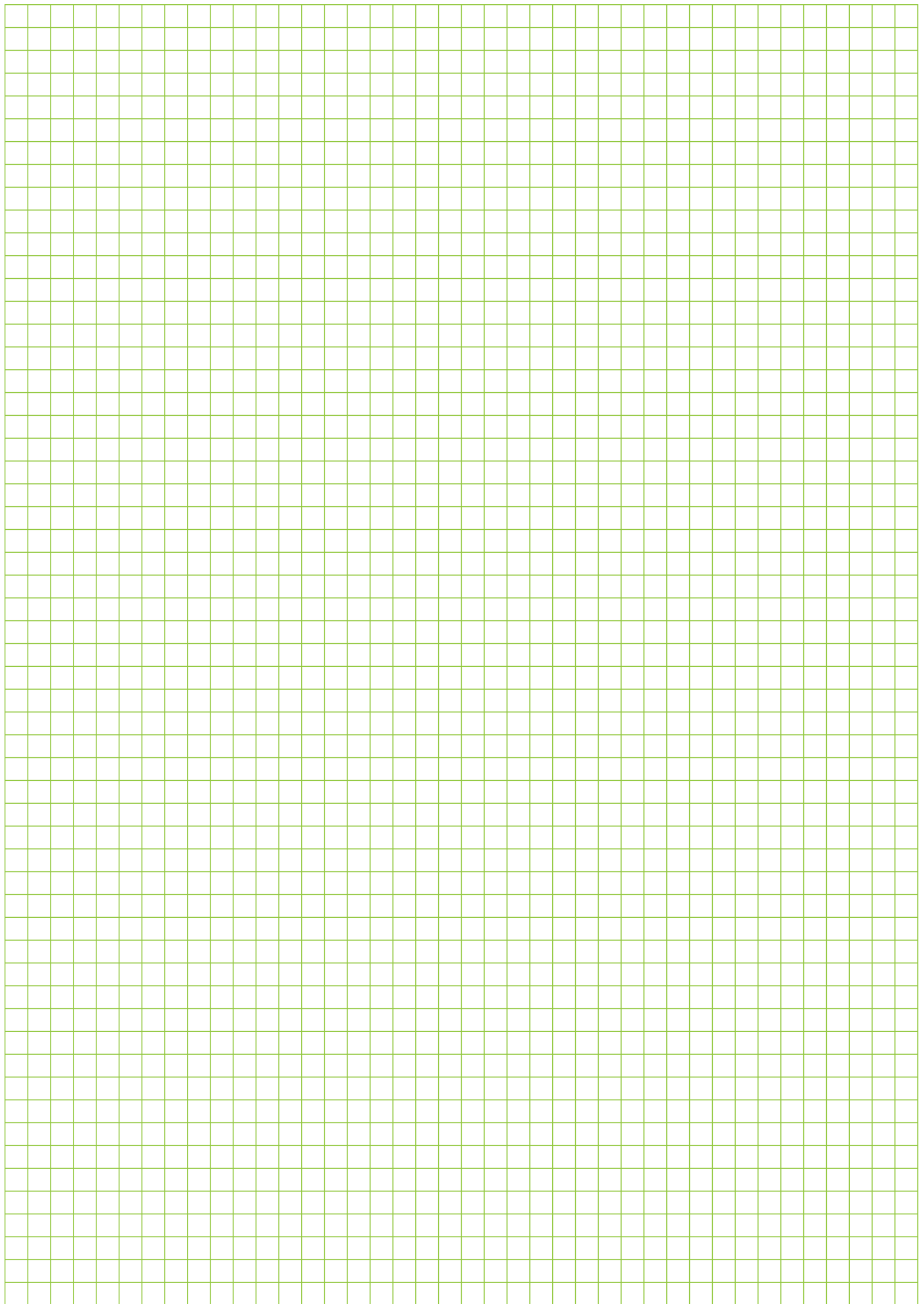

Družstevní závody Dražice-strojírna s.r.o.
Dražice 69, 294 71 Benátky nad Jizerou
Česká republika

Tel.: +420/326 370 990
Fax: +420/326 370 980
E-mail: prodej@dzd.cz
www.dzd.cz

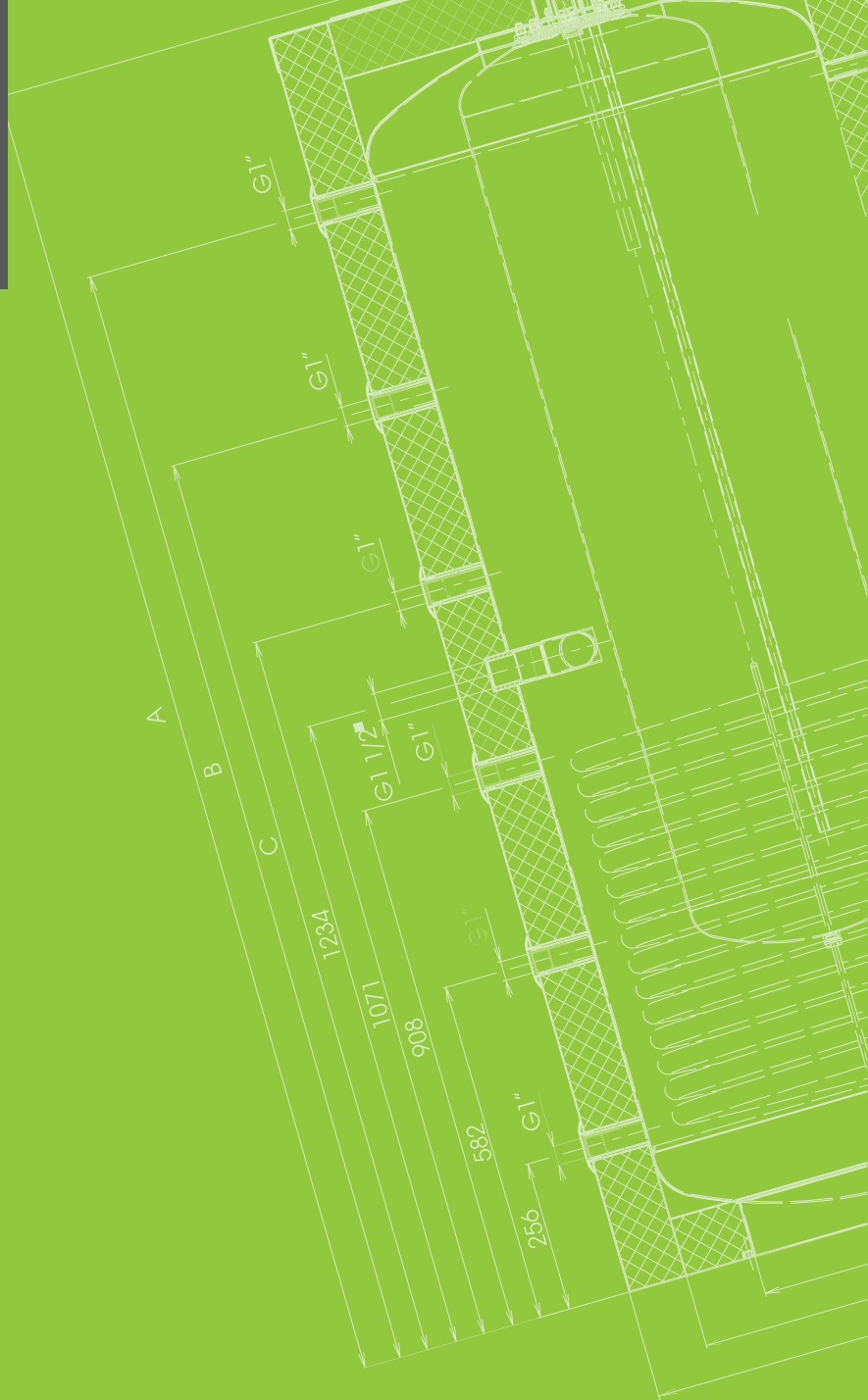

© September/2018
The current version can be found on www.dzd.cz.
The manufacturer reserves the right to changes.

PROUD
PARTNER OF

